

Ligne de Produits

Logiciels

Vue générale, principes

Mathieu Acher
Maître de Conférences
mathieu.acher@irisa.fr



Material

<http://mathieuacher.com/teaching/MDI/>

Plan

- Challenges and Overview
 - Developing billions of software product is hard but now a common practice
- Implementing Variability
 - Revisit of existing techniques and curriculum
- Specificity of Product Line Engineering
 - Process, methods
- Feature Models
 - Defacto standard for modeling product lines and variability

Contract

- The idea of software product lines and variability
 - You will be able to recognize this class of systems
 - Aware of the complexity
 - Aware of the specific development process
 - Aware of existing techniques
- Feature modeling
 - A widely used formalism for modeling product lines and configurable systems in a broad sense

Software Product Line and Variability Engineering

Challenges and Overview

Trois manières de construire un produit (logiciel)

Indépendamment

„Clone & Own“

Assets „partagés“

Lignes de produits logiciels

Configuration de produits
Modélisation de la variabilité
Composants
Langages dédiés
Générateurs
Préprocesseurs
Patrons de conceptions
...



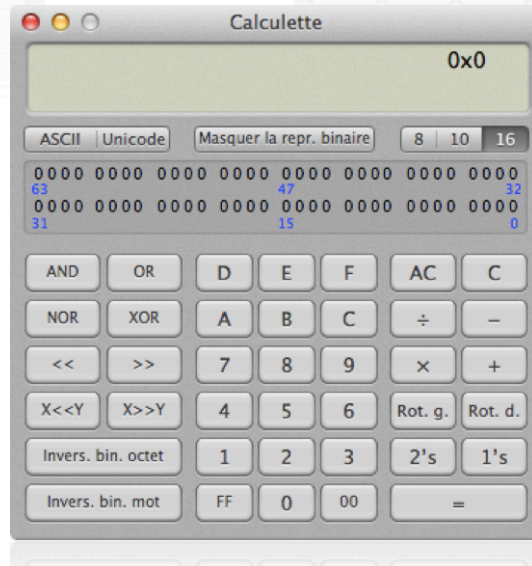
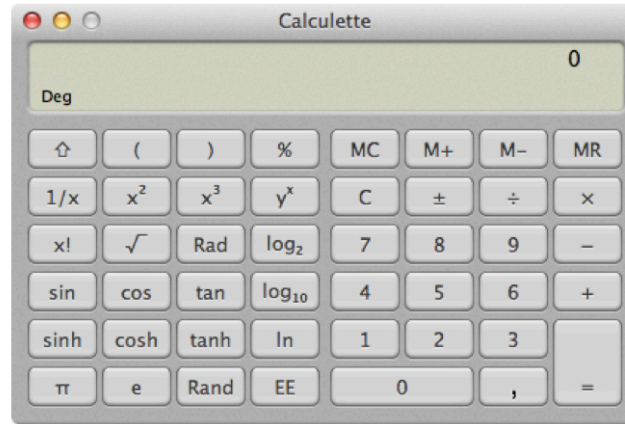
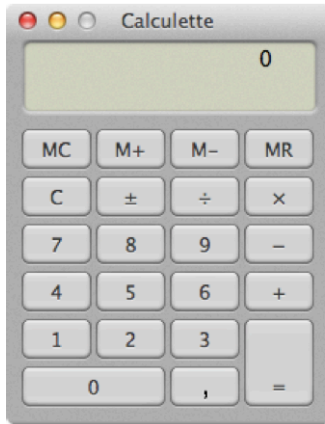

« A set of programs is considered to constitute a **family**, whenever it is worthwhile to study programs from the set by **first studying the common properties** of the set and then determining the **special properties** of the individual family members »

aka Variability

David L. Parnas — “On the design and development of program families” in Transactions on Software Engineering, SE-2(1):1–9, 1976



Starter



Home Premium Upgrade

\$119.99*

Buy



Professional Upgrade

\$199.99*

Buy



Ultimate Upgrade

\$219.99*

Buy

Communication

Bluetooth support	✓	✓	✓	✓
Join a homegroup	✓	✓	✓	✓
Internet Explorer 8	✓	✓	✓	✓
View Available Networks	✓	✓	✓	✓
Windows Connect Now (WCN)	✓	✓	✓	✓
Create a homegroup		✓	✓	✓
Location and other sensors support		✓	✓	✓
Support for joining domains			✓	✓

Entertainment

DirectX 11	✓	✓	✓	✓
Gadgets	✓	✓	✓	✓
Games Explorer	✓	✓	✓	✓
Play To	✓	✓	✓	✓
Windows Media Player 12	✓	✓	✓	✓
Create and play DVDs		✓	✓	✓
Internet TV		✓	✓	✓

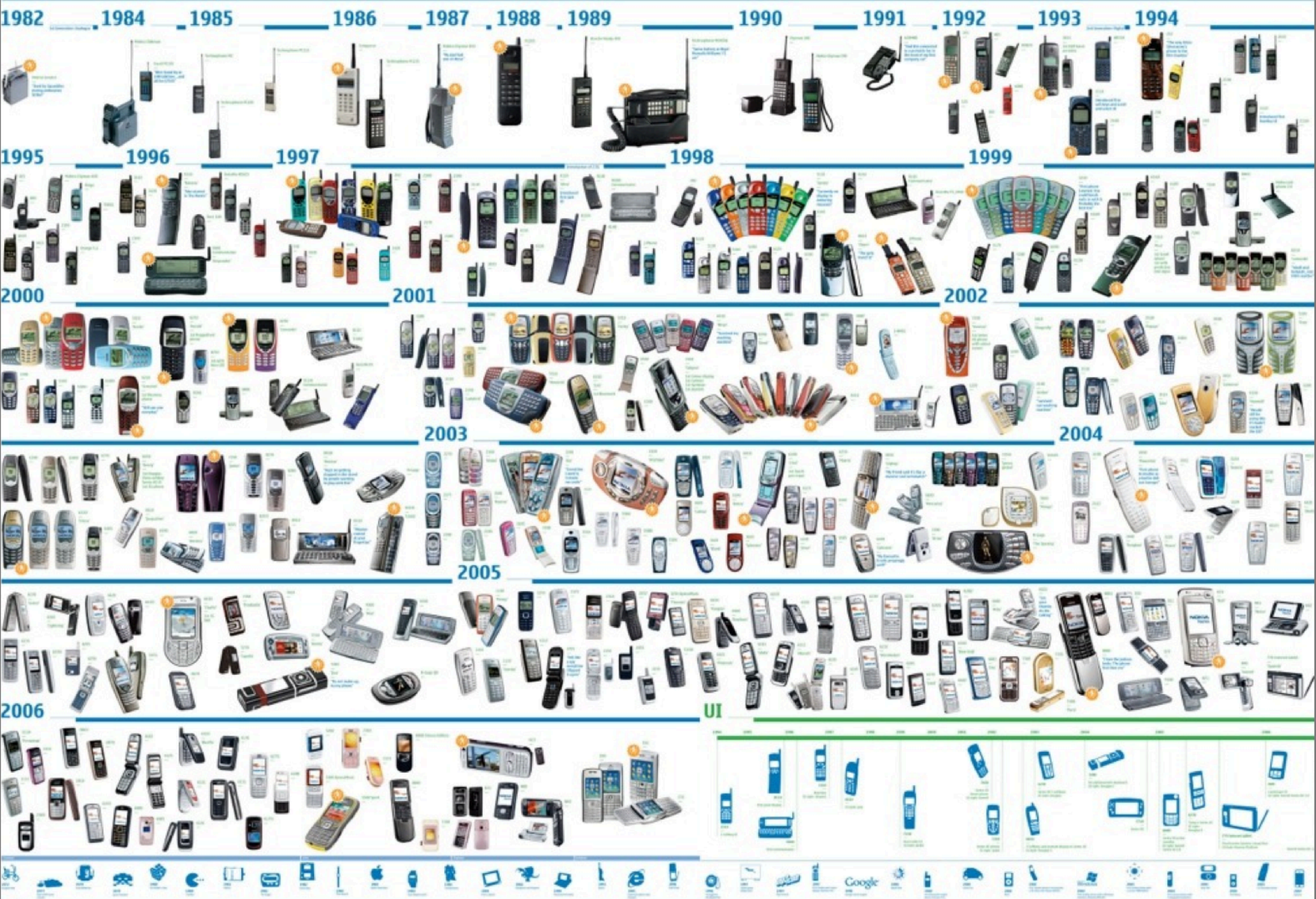



Software-intensive systems

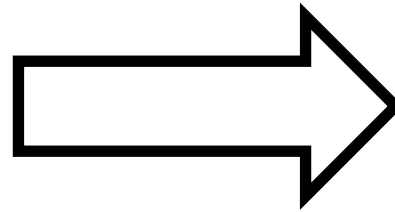

come in many variants

Software Product Line Engineering

Factoring out **commonalities**

for **Reuse** [Krueger et al., 1992] [Jacobson et al., 1997]

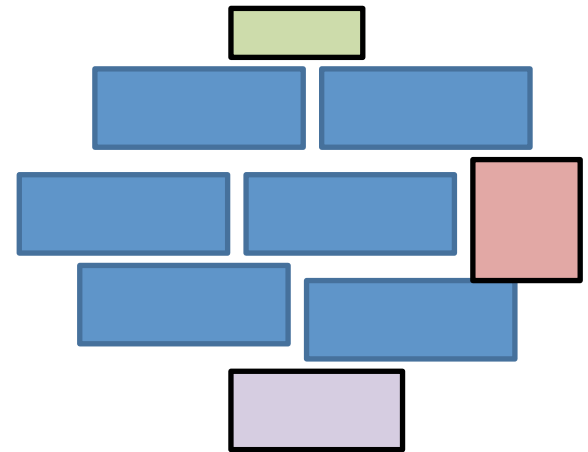

Managing **variabilities**

for Software **Mass Customization** [Bass et al., 1998] [Krueger et al., 2001], [Pohl et al., 2005]



Variability

“the ability of a system to be efficiently extended, changed, customized or configured for use in a particular context”

Mikael Svahnberg, Jilles van Gorp, and Jan Bosch (2005)



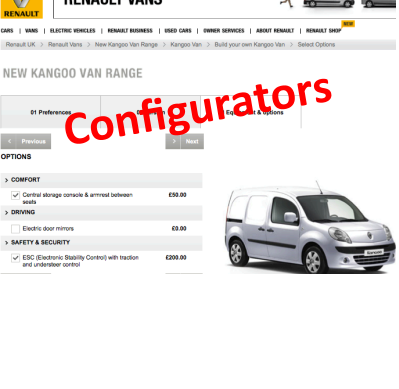

Configurators



Comparison of*

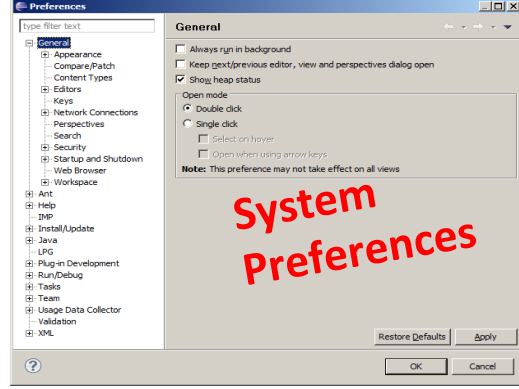

System Preferences

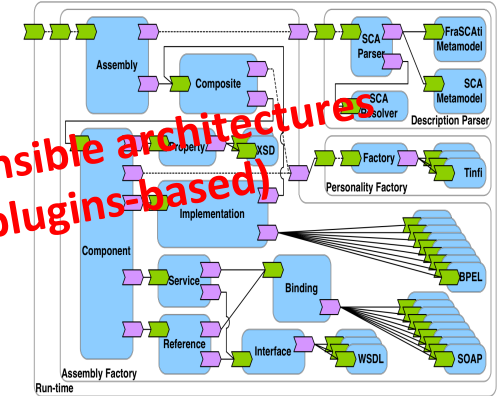

Extensible architectures (eg plugins-based)

External Variability Internal Variability Variability @ run.time

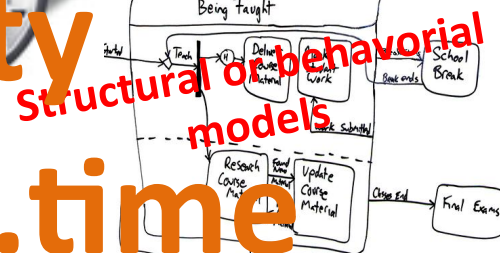

Structural or behavioral models

```
httpd.conf -- win32 Apache
Building a Web Server, for Windows

Listen 80
ServerRoot "/www/Apache2"
DocumentRoot "/www/webroot"

ServerName localhost:80
ServerAdmin admin@localhost

ServerSignature On
ServerTokens Prod
ServerProtocol http
DefaultCharset ISO-8859-1
UseCanonicalUrl Off
HostNameLookups Off
ErrorLog logs/error.log
LogLevel error
PidFile logs/httpd.pid

KeepAlive On
MaxKeepAliveRequests 100
KeepAliveTimeout 15

<IfModule mpm_winnt.c>
  ThreadsPerChild 250
  MaxRequestsPerChild 0
</IfModule>
```

Configuration files

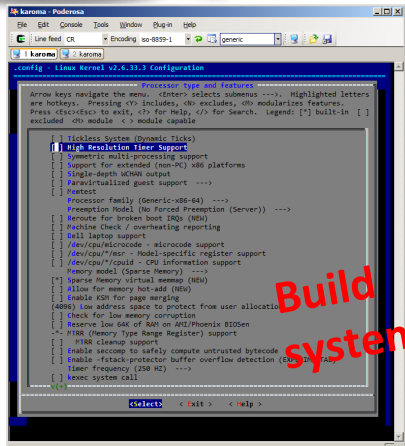

Build systems

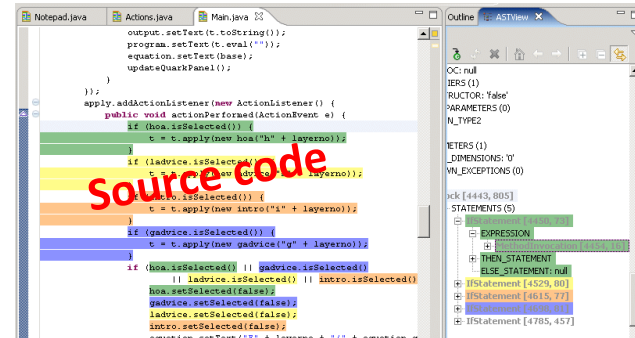

source code

- Developer Tools
 - Development
 - Drivers
 - DTP/Prepress
 - Educational
 - Finance
 - Font Tools
 - Games
 - Graphics
 - HTML Tools
 - Internet Utilities
 - iPhone Applications
 - iPod Tools
 - Math/Scientific
 - Multimedia
 - Network/Admin
 - Screensaver
 - Security
 - Spotlight Plugins/Utilities
 - System Utilities
 - Video
 - Word Processing
-
- GLOBAL PAGES >>
 - NEWS ARCHIVE >>
 - DFTPEdia REVIEWS >>
 - MEET THE EDITORS >>

Power Matte 2.0 1.3 update



Adobe Bridge plug-in that can extract a subject in an image

[read more >]

Size:	13.20 MB
Platform:	Mac OS X 10.5 or later
License:	Trial
Rating:	Good (3.0/5)
Downloads:	1,504
Updated:	June 20th, 08:21 UTC

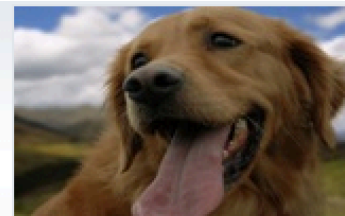

Grids 1.1 update



Helps you generate perspective grids

[read more >]

Size:	102 KB
Platform:	Mac OS X 10.8 or later
License:	Commercialware
Rating:	NOT RATED
Downloads:	21
Updated:	June 20th, 07:56 UTC

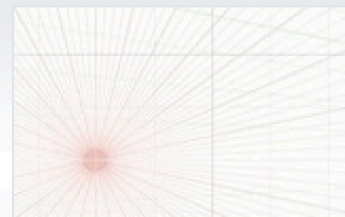

Picture Frame 2.2 update



Quickly generate multi-frame photos using your Mac

[read more >]

Size:	716 KB
Platform:	Mac OS X 10.6.6 or l...
License:	Commercialware
Rating:	Excellent (5.0/5)
Downloads:	297
Updated:	June 20th, 07:53 UTC



FashionLab Studio 1.1 update



Makes it easy to design your own T-shirt using a Mac

[read more >]

Size:	3.10 MB
Platform:	Mac OS X 10.6.6 or l...
License:	Commercialware
Rating:	NOT RATED
Downloads:	3
Updated:	June 20th, 07:49 UTC

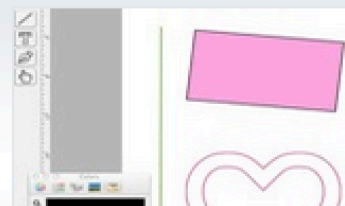



RENAULT VANS



CARS | VANS | ELECTRIC VEHICLES | RENAULT BUSINESS | USED CARS | OWNER SERVICES | ABOUT RENAULT | RENAULT SHOP

NEW

Renault UK > Renault Vans > New Kangoo Van Range > Kangoo Van > Build your own Kangoo Van > Select Options

NEW KANGOO VAN RANGE

01 Preferences

02 Version

03 Equipment & options

< Previous

> Next

OPTIONS

> COMFORT

Central storage console & armrest between seats **£50.00**

> DRIVING

Electric door mirrors **£0.00**

> SAFETY & SECURITY

ESC (Electronic Stability Control) with traction and understeer control **£200.00**



Variability

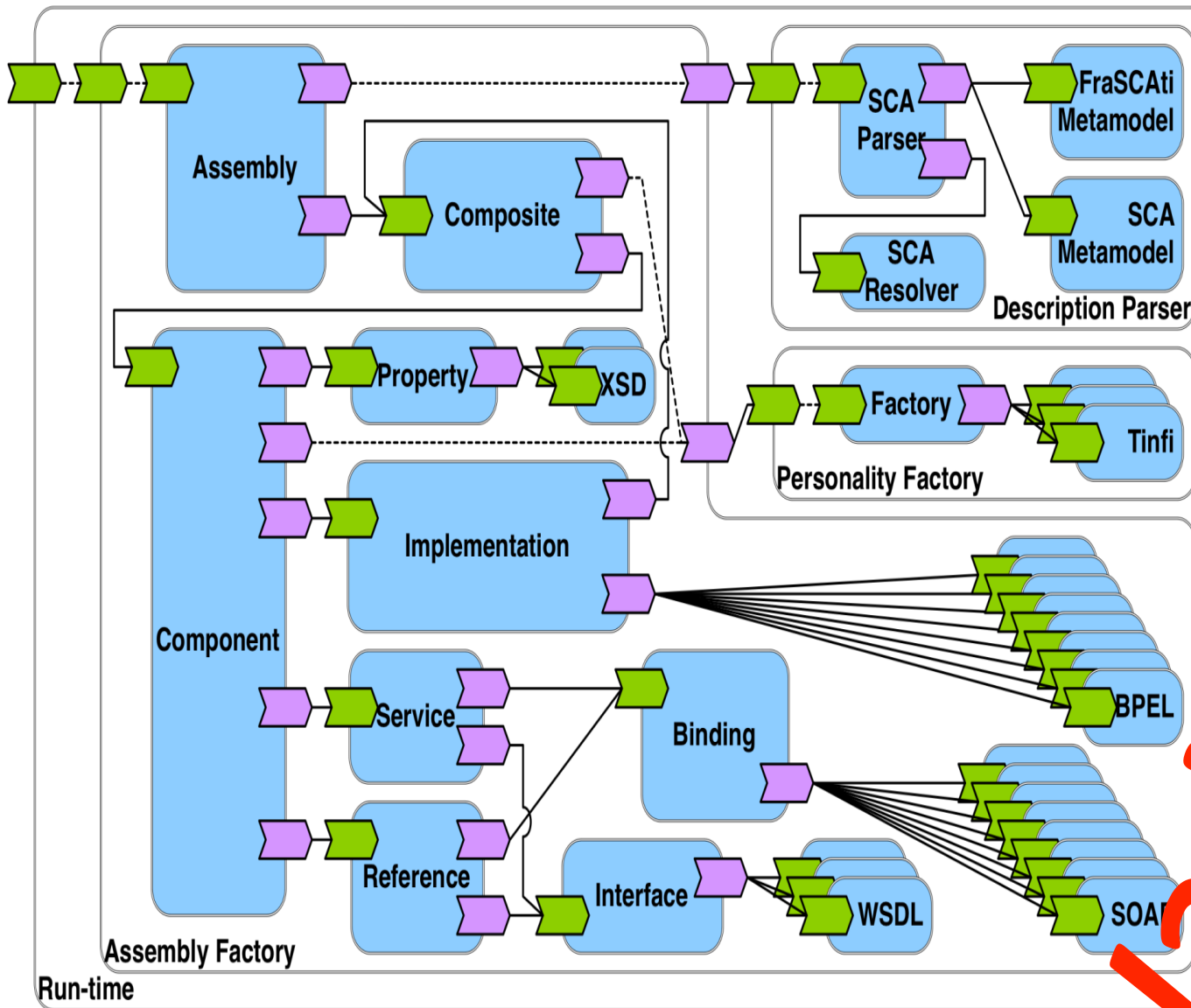

Variability

Run-time

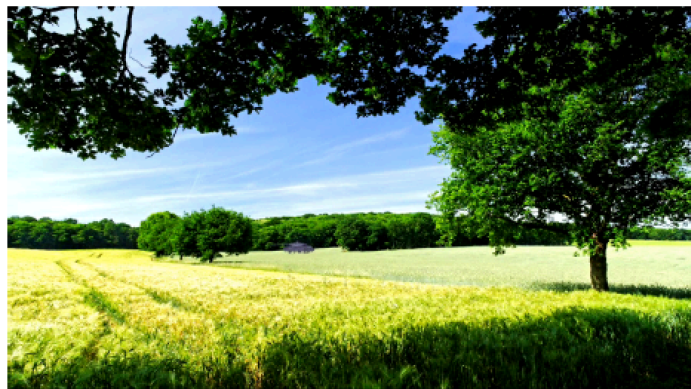

(a) Variant #1 of video sequence



(b) Variant #2 of video sequence



(c) Variant #3 of video sequence



(d) Variant #4 of video sequence



(e) Variant #5 of video sequence

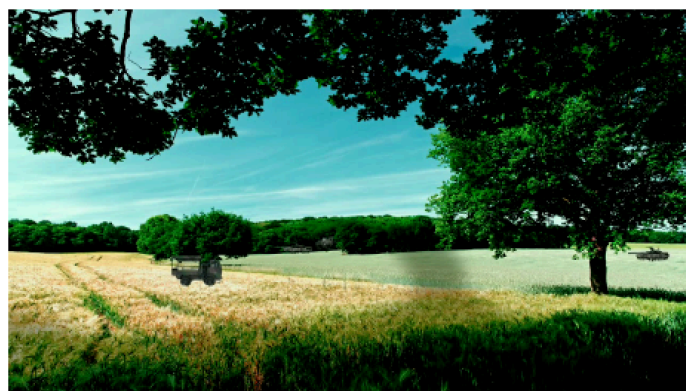

(f) Variant #6 of video sequence

Figure 1: Six variants of video sequences synthesized with ViViD

```
/* [Customize body] */
```

```
//Set the outside length of your pencil box.  
length=190;//[70:400]
```

```
//Set the outside depth of your pencil box.  
depth=70;//[50:400]
```

```
//Set the total height of your pencil box. The top of the box is set at 15mm.  
//Extra height is added to the body section.  
height=40;//[40:150]
```

```
//Choose divider orientation. Long is for the X direction.
```

```
long = 1;//[0,1,2]
```

```
//Short is for the Y direction.
```

```
short = 2;//[0,1,2,3]
```

```
//When you have 2 long dividers,
```

```
// picking yes here will put short dividers in the center section.
```

```
center = 0;//[1:Yes,0:No]
```

1

Lid inside settings

Lid inside content

Lid outside

Customize body

Design key

Customize ruler

Printer platform settings

Length Set the outside length of your pencil box. 190

Depth Set the outside depth of your pencil box. 70

Height Set the total height of your pencil box. The top of the box is set at 15mm. Extra height is added to the body section. 40

Long Choose divider orientation. Long is for the X direction.

Short Short is for the Y direction.

Center When you have 2 long dividers, picking yes here will put short dividers in the center section.

Customizable Battery Case



Like	284
Collect	473
Comment	20
I Made One	8
Watch	10
Remix It	366
Share	

Open in Customizer
Download This Thing!



Thing Info	Instructions	Thing Files	20 Comments	8 Made	473 Collections	366 Remixes
------------	--------------	-------------	-------------	--------	-----------------	-------------

Description
A customizable battery case to hold batteries while traveling. Configurable for the number of batteries and type (as long as they're cylindrical). This is an updated version of the customizable battery carrier (thingiverse.com/thing:51376), re-designed to work without magnets as requested by GregFlak25.

20865 Views 2444 Downloads
Found in Containers
Report Thing as inappropriate
Makes view more >

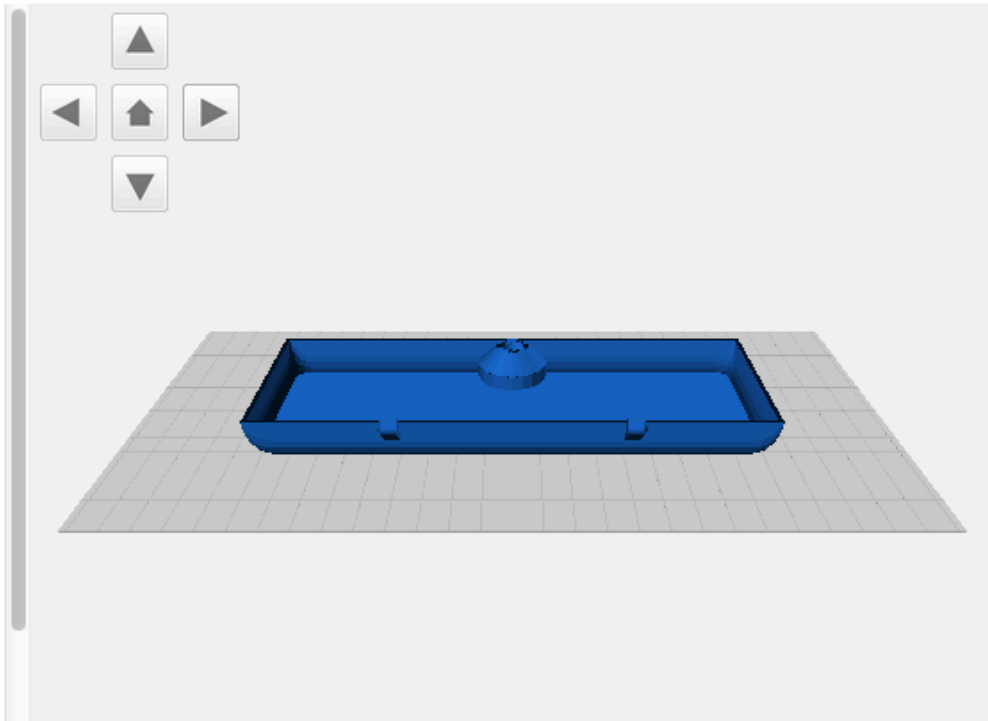

Variability in time vs in space

- **Variability in Time (releases)**
 - the existence of different **versions** of an artifact that are valid at different times
- **Variability in Space (variants)**
 - the existence of an artifact in different **shapes** at the same time

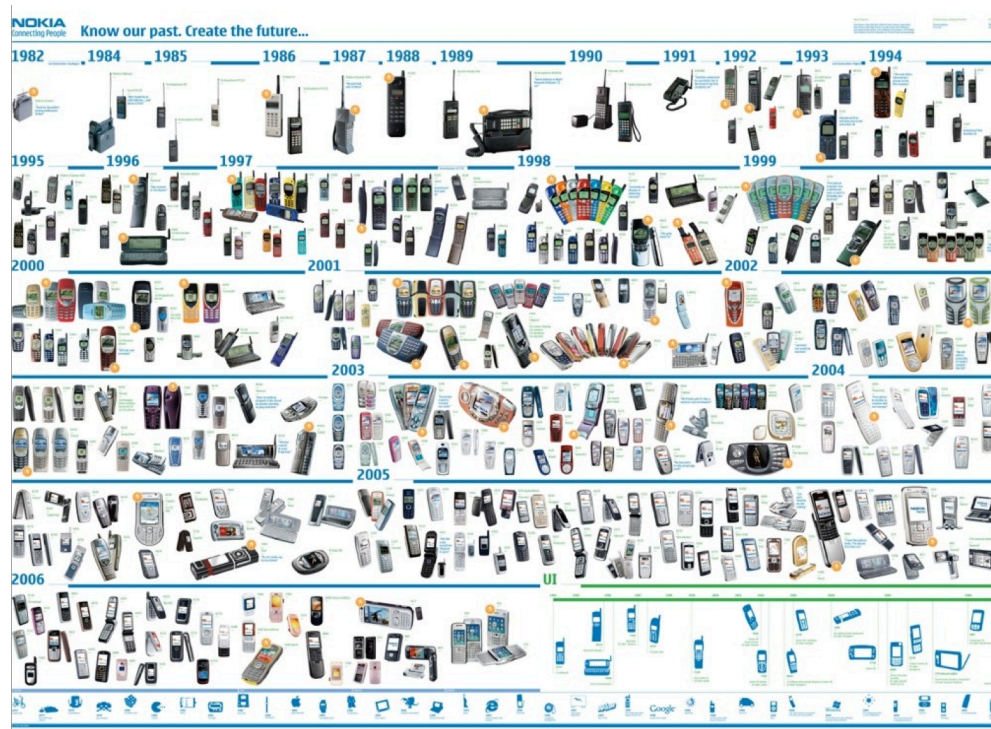

Benefits

Improve product reliability

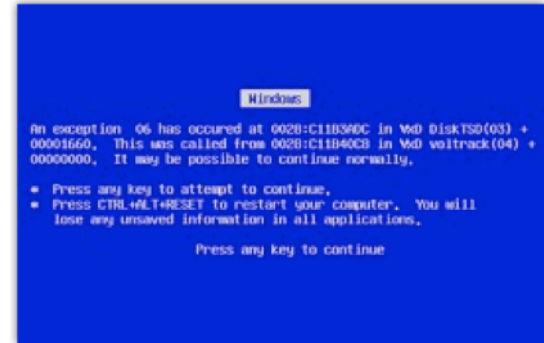

Improve usability



Improve consistency across products...

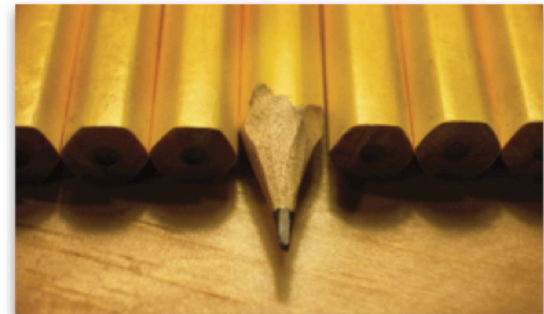

Benefits

Reduce production costs



Reduce certification costs



Shorten time-to-market



Hall of Fame

splc.net/fame.html



Lucent Technologies
Bell Labs Innovations



CelsiusTech



Printer Firmware

- Production cost reduced by 75%
- Development time reduced by 33%
- Reported defects reduced by 96%



A Bit of History: Industrial Revolution

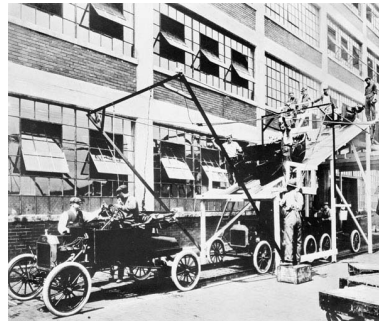

1901
Henry Ford

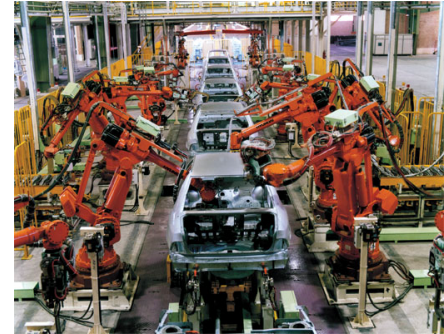

1980s

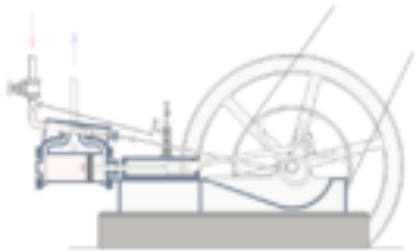

1698
Thomas Savery

Nowaday: Product Lines Everywhere



Product Lines of Cars



Exterior | Interior

Side | Front | Rear

360°



This image may contain optional equipment. 360°

Agila, Club
1.2i 16v, 5 Speed
Blaze Red, Melt / Elba Charcoal

Total € 15,684.00

1. Trims/Series 2. Engine/Transmission 3. Colour & Style 4. Options 5. Summary Next Step

Choose Your Options

Audio/Comms/Nav Heating/Ventilation Mechanical Safety/Security **A-Z**

Audio/Comms/Nav	
<input checked="" type="checkbox"/> CD 30 Standard	- MP3 CD player with MP3 format, stereo radio, steering wheel mounted audio controls
Heating/Ventilation	
<input checked="" type="checkbox"/> Air conditioning € 923.00	
Mechanical	
<input checked="" type="checkbox"/> Electronic Stability Programme (ESP) € 411.00	
Safety/Security	
<input checked="" type="checkbox"/> Emergency tyre inflation kit in lieu of space-saver spare wheel and tyre Standard	

Audio/Comms/Nav Heating/Ventilation Mechanical Safety/Security **A-Z**

Next Step: Summary

Legend

- Selected Option
- Selectable Option
- Option contained in an option pack
- Option contained in an option pack or standard equipment which has been replaced by another option
- Option that is only selectable together with another option. Please click for details

Pricing Details

Club	€ 14,350.00
1.2i 16v, 5 Speed	
Blaze Red	€ 0.00
Melt / Elba Charcoal	€ 0.00
15-inch steel wheels with 185/60 R 15 tyres and flush wheel covers	€ 0.00
Options (2)	-
You selected:	
<input checked="" type="checkbox"/> Air conditioning	€ 923.00
<input checked="" type="checkbox"/> Electronic Stability Programme (ESP)	€ 411.00
Total	€ 15,684.00

Willkommen bei selve - the shoe individualizer

http://www.selve.net/index_js.html

KOLLEKTION FUSSTYP MYSELVE INFO HOME selve

MODELLE
LOOKBOOK

SELVE ID
PASSWORT
>>ANMELDEN

selve

selve Kollektion -> Style: [casuals](#) -> Modell: [Opal](#)

modell-details
>>hier klicken

>>SELVE SCHUHREGAL
inhalt: 0

>>SHOPPING BAG
inhalt: 0



A. Erstes Oberleder
Veloursleder Sand

B. Veloursleder Bordeaux
Veloursleder Cognac
Veloursleder Sand

C. Futterleder
Beige

D. Absatz
Hufeisen Braun

E. Sohle
Gummisohle

>>ÄNDERN
>>ZURÜCKLEGEN

Müsli individuell online mixen! Bio-Müsli. - Mozilla Firefox

File Edit View History Bookmarks Tools Help

http://www.mymuesli.com/muesli/index.php?vw=mixer&ec=step1&mid=1&mnpt=1&type=t0

Müsli individuell online mixen! Bio-M...

my**muesli**
custom-mixed cereals

muesli mixer blog fragen about us

Müslibasis

Basis verfeinern

Früchte

Nüsse & Kerne

Extras

Früchte

Köstliche Bio-Trockenfrüchte, müsligerecht aufbereitet. Du kannst eine Frucht auch mehrmals auswählen, um deren Anteil zu steigern.

Ananas
lecker, exotisch und wunderbar | 0.65€ (30g)
[mehr Infos](#)

Apfelstücke
Ohne Worte weil Klassiker | 0.45€ (25g)
[mehr Infos](#)

Aprikosen

hoch ▲ ▼ runter

Apfelstücke
Buchweizenflocken
C'Mohn, baby!

Nährwerte pro 100g ▲
575g nur 4,70€
entspricht 8,17€/kg
inkl. MWSt., zzgl. Versandkosten

fertig gemixt?
weiter

©2011 mymuesli GmbH
Öko-Kontrollstelle DE-037
[Impressum](#)

Done en-US

Der Dell Online-Shop: Stellen Sie Ihr eigenes System zusammen - Mozilla Firefox

File Edit View Go Bookmarks Tools Help

http://configure2.euro.dell.com/dellstore/config.aspx?c=de&cs=dedhs1&kc=305&l=de&oc=W06390xp&s=dhs&sbc=pr

Getting Started Latest Headlines

Bestellen Sie online oder wählen Sie 0800 533 55 40 (gebührenfrei)

DELL Produkte Service Support Einkaufsunterstützung

Suche

Dell empfiehlt Windows Vista™ Home Premium.

Sie befinden sich hier: Deutschland > PRIVATANWENDER

1 Meinen Dell konfigurieren 2 Zubehör auswählen 3 Elektronik 4 Software & Service 5 Bestätigen & zum Warenkorb

Als Symbol anzeigen

ELC DDR2-Speicherspeicher mit 4,0 GB und 667 MHz (2 x 2,0 GB DIMM) [plus 019,99 € oder 20 €/Monat¹]

Grafikkarte

128 MB nVidia NVS285 DVI/VGA-Grafikkarte

Auswahlhilfe

- 256 MB ATI Fire GL V7200-Grafikkarte [plus 416,50 € oder 13 €/Monat¹]
- 128 MB nVidia Quadro FX550-Grafikkarte [plus 69,02 € oder 2 €/Monat¹]
- 256 MB nVidia Quadro FX3450-Grafikkarte [plus 547,40 € oder 17 €/Monat¹]
- 128 MB nVidia NVS285 DVI/VGA-Grafikkarte [Im Preis enthalten]
- Grafikkarte PCIe x16 (DVI/VGA) Matrox QID LP PCIe, 128 MB, DVI- oder VGA-Grafikkarte für 4 Monitore [plus 630,70 € oder 20 €/Monat¹]
- 128 MB ATI Fire GL V3400-Grafikkarte [plus 44,03 € oder 1 €/Monat¹]

Festplatte

80 GB Serial ATA-II-Festplatte (7.200 U/min) mit NCQ

Auswahlhilfe

- 160 GB Serial ATA-II-Festplatte (7.200 U/min) mit NCQ [plus 16,66 €]
- 80 GB Serial ATA-II-Festplatte (7.200 U/min) mit NCQ [Im Preis enthalten]

Finanzierung ab **30 €/mtl.**²
Jetzt finanzieren - erst ab Januar 2008 zahlen!
Weitere Informationen zur Ratenfinanzierung

Dell Precision™ 390 Essential (W06390xp)

inkl. MwSt., zzgl. 19,04 € Versand
Ermäßigter Sonderpreis
913,92 €
Es gelten keine zusätzlichen Preisnachlässe.
Das Angebot gilt für maximal 5 Systeme

Für einen noch umfassenderen Schutz Ihres Systems beinhaltet der oben erwähnte Preis ein Upgrade Service Paket. Um auf den beworbenen Preis zu kommen, entmarkieren Sie die Kategorie "Business Support".

Transferring data from i.dell.com...

Food? Product lines!

VEGETARIAN

WHICH WICH WOULD YOU LIKE?

↓

TRIPLE CHEESE MELT
 ELVIS WICH (P.F., Honey & Banana)
 TOMATO & AVOCADO
 BLACK BEAN PATTY
 HUMMUS & BELL PEPPERS

CHOOSE YOUR BREAD

↓

WHITE WHEAT

CHOOSE YOUR CHEESE (Optional)

↓

AMERICAN SWISS PROVOLONE
 CHEDDAR PEPPER JACK MOZZARELLA

How Would You Like Your WICH Worked?

↓

MUSTARDS
 Yellow Dijon Honey Deli

MAYOS
 Regular Lite Horseradish Spicy

SPREADS & SAUCES
 BBQ Buffalo Marinara
 1000 Island Ranch

ONIONS







Mass production

**What about
software?**

Product lines of software intensive systems

Software intensive systems
are declined in many **variants**

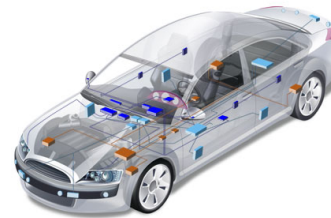
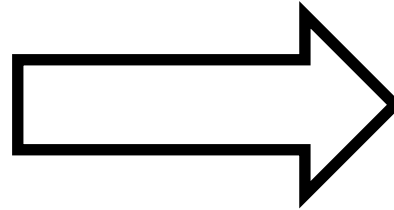

Software intensive systems
are declined in many **variants**

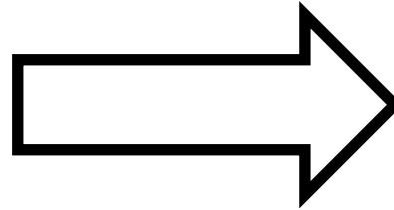

Software Product Lines

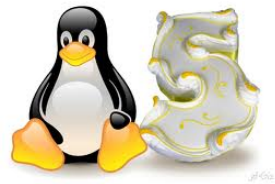

01011011
11011110
0011110
11001101
10001111
10100010
10001010
10101011
00001110
11010101
10111010
01100100
01010101
11010110
.....



Car

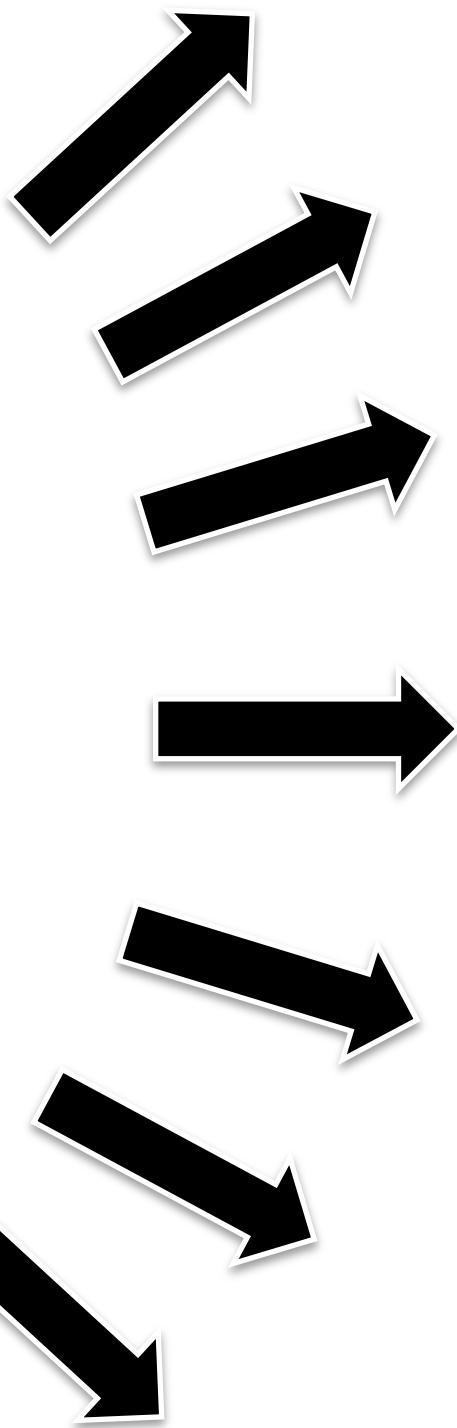

Database Engine

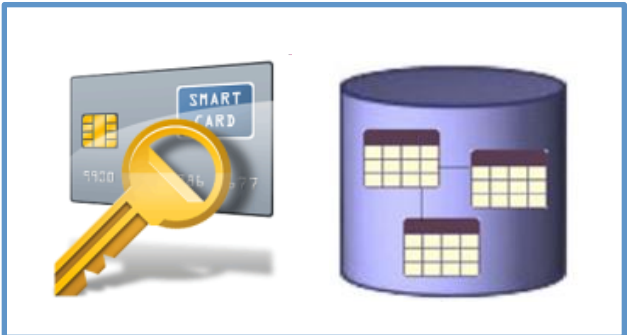
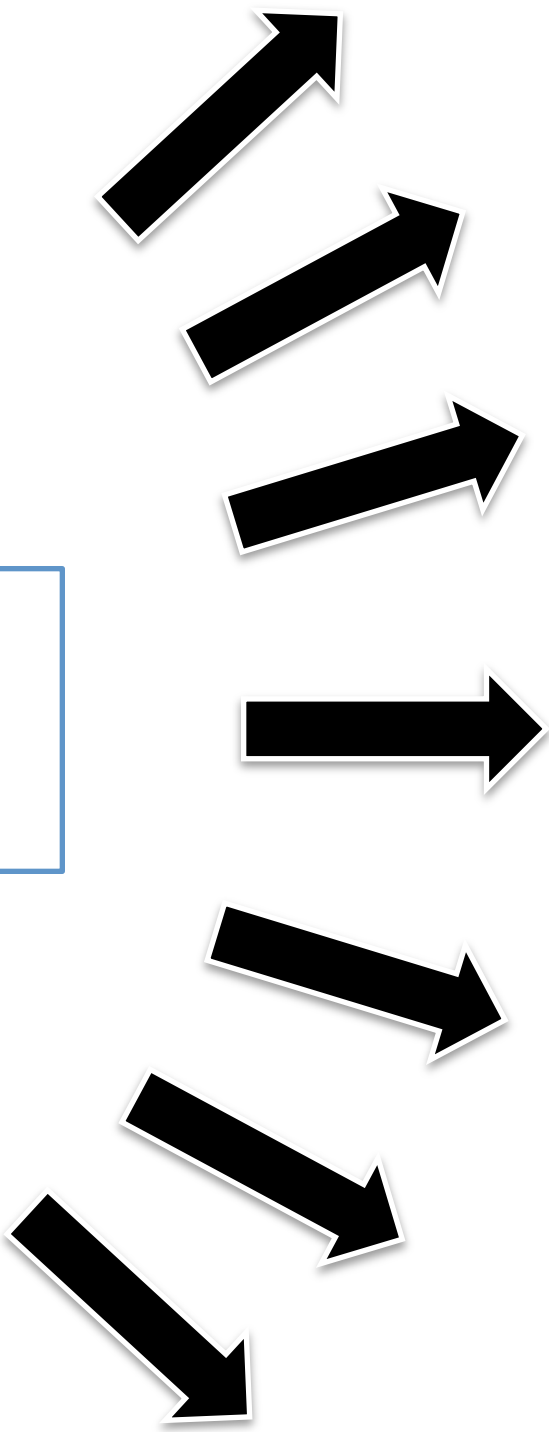

Printer
Firmware

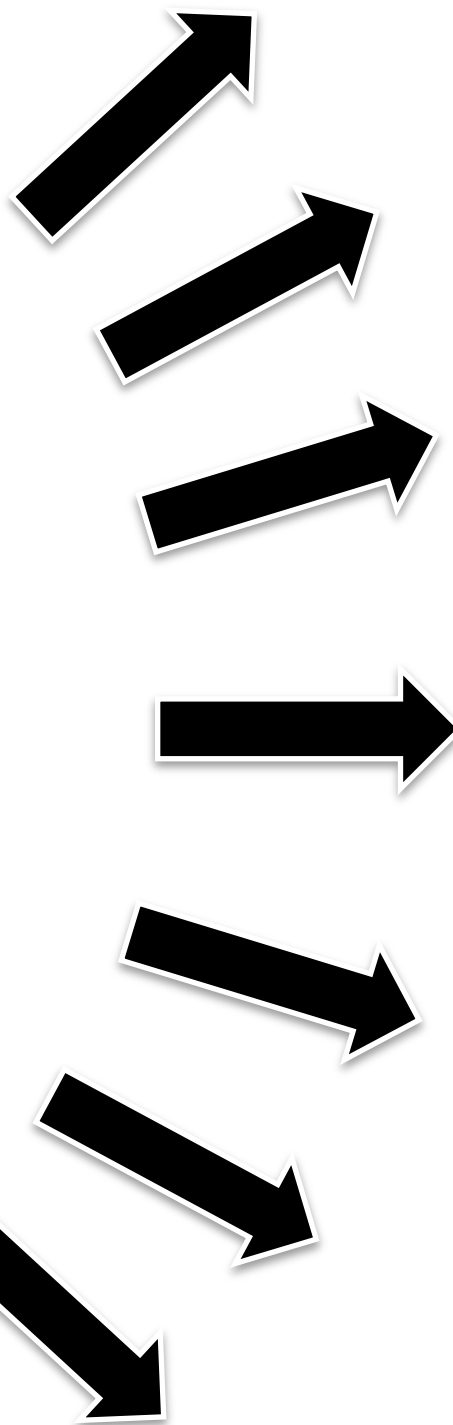

```
karoma Encoding iso-8859-1 generic
.config - Linux Kernel v2.6.33.3 Configuration
-----
Processor type and features
Arrow keys navigate the menu. <Enter> selects submenus ---. Highlighted letters
are hotkeys. Pressing <Y> includes, <N> excludes, <M> modularizes features.
Press <Esc><Esc> to exit, <?> for Help, </> for Search. Legend: [*] built-in [ ]
excluded <M> module < > module capable

[ ] Tickless System (Dynamic Ticks)
[*] High Resolution Timer Support
[ ] Symmetric multi-processing support
[ ] Support for extended (non-PC) x86 platforms
[ ] Single-depth WCHAN output
[ ] Paravirtualized guest support ---
[ ] Memtest
Processor family (Generic-x86-64) ---
Preemption Model (No Forced Preemption (Server)) ---
[ ] Reroute for broken boot IRQs (NEW)
[ ] Machine Check / overheating reporting
[ ] Dell laptop support
[ ] /dev/cpu/microcode - microcode support
[ ] /dev/cpu/msr - Model-specific register support
[ ] /dev/cpu/* /cpuid - CPU information support
Memory model (Sparse Memory) ---
[*] Sparse Memory virtual memmap (NEW)
[ ] Allow for memory hot-add (NEW)
[ ] Enable KSM for page merging
(4096) Low address space to protect from user allocation
[ ] Check for low memory corruption
[ ] Reserve low 64K of RAM on AMI/Phoenix BIOSen
-- MTRR (Memory Type Range Register) support
[ ] MTRR cleanup support
[ ] Enable seccomp to safely compute untrusted bytecode
[ ] Enable -fstack-protector buffer overflow detection (EXPERIMENTAL)
[ ] Timer frequency (250 HZ) ---
[ ] kexec system call
v(y)
<select> <exit> <help>
```

Linux Kernel

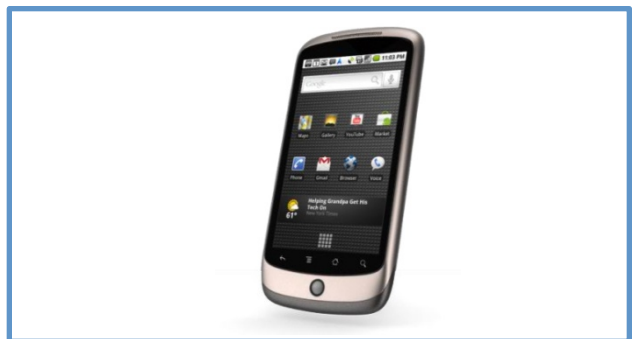
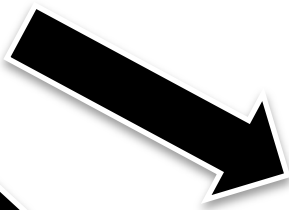
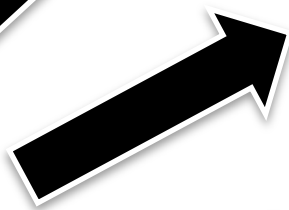
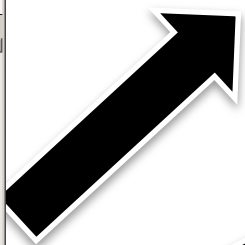

Linux-Kernel

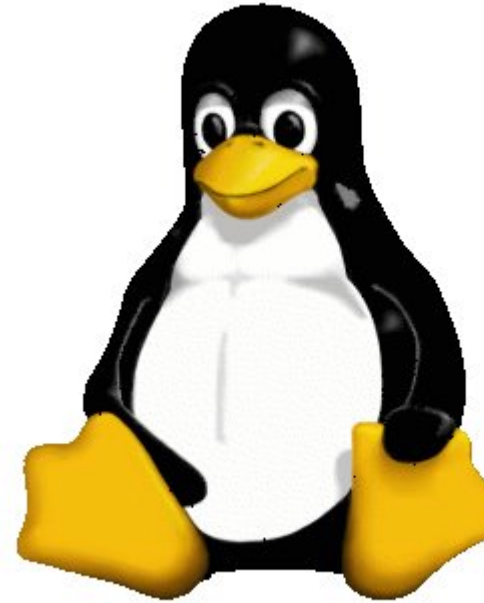

Features in Microsoft Office

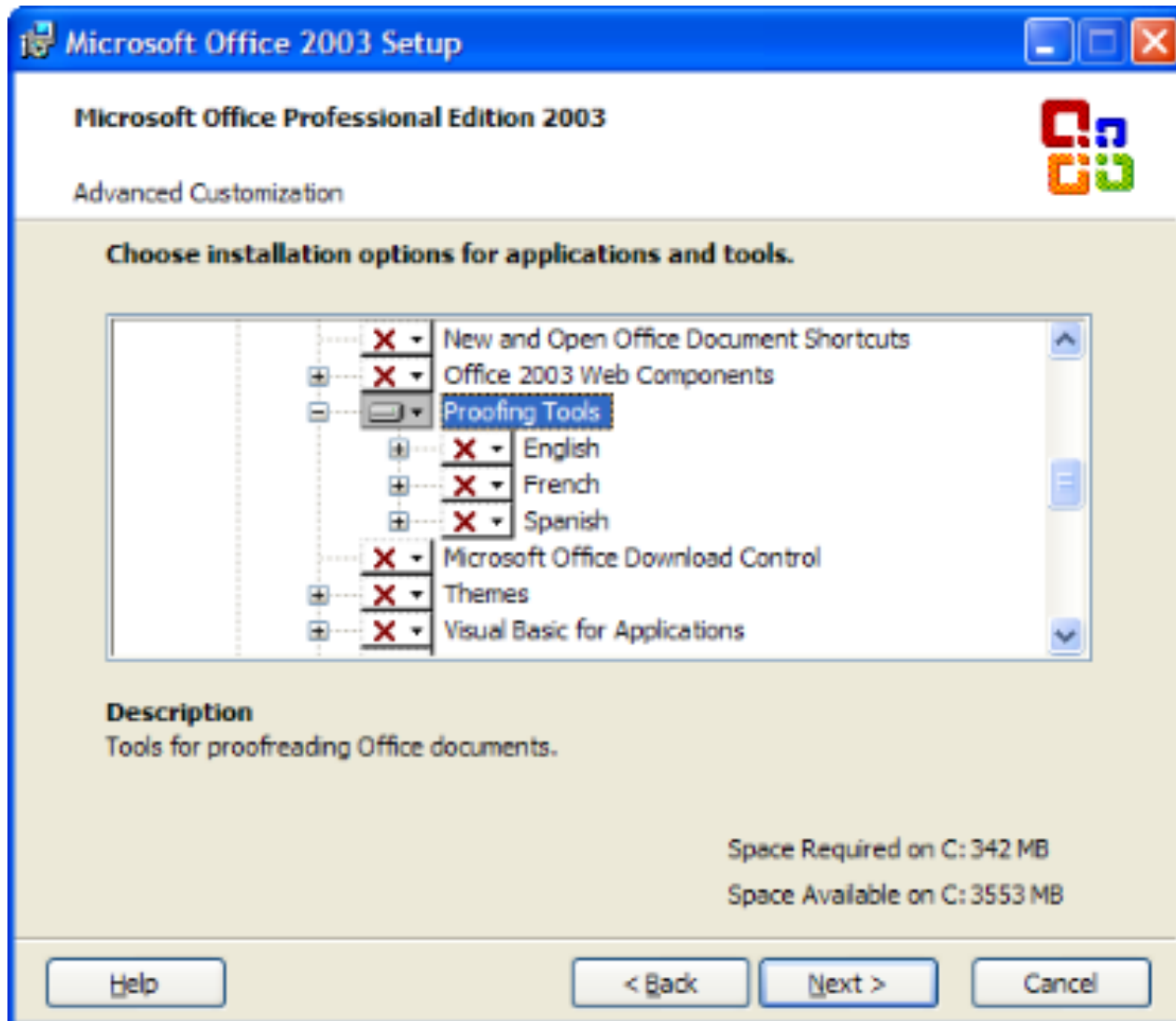

Bref

bref.
CANAL a 30 ans.

ETAPE 1 : DONNE TON PRENOM

MATHIEU

→ OK

Online Generator

← → C bref30ans.canalplus.fr/#c

ETAPE 2 : CHOISIS 3 BONS SOUVENIRS



Variant

← → ↻ bref30ans.canalplus.fr/#video

ETAPE 3 : JE REGARDE MON EPISODE UNIQUE

DEJÀ 761 545 EPISODES GENERES.

MATHIEU +
présente

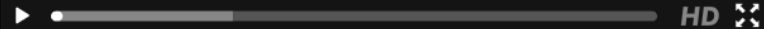

POWERED BY MICROSOFT AZURE

Quizz Time

← → ↻ socrative.com



Apps

Resources

About

Help

STUDENT LOGIN

TEACHER LOGIN

Welcome to Socrative!

Enter your teacher's room below

Room Name

Join Room

e9a8d603

Quizz Time

e9a8d603

Give three examples of software product lines
(also called configurable systems or variability-
intensive systems)

Variability

“the ability of a system to be efficiently extended, changed, customized or configured for use in a particular context”

Mikael Svahnberg, Jilles van Gorp, and Jan Bosch (2005)



A 3D maze background with the text "Variability = Complexity" overlaid. The maze is composed of white walls and paths, creating a complex, winding structure that recedes into the distance. The text is centered in the upper portion of the image.

Variability = Complexity

33 optional, independent features



a unique variant for every
person on this planet

320^{optional, independent} features

more variants than estimated
atoms in the universe



2000 features

10000 features



Automation?

Avoid solving the same problem!

2, 3...n times



Correctness



A stop error has been detected and windows has been shut down to prevent damage to your computer.

PAGE_FAULT_IN_NONPAGED_AREA

If this is the first time you've seen this stop error screen, restart your computer. If this screen appears again, follow these steps:

Check to make sure any new hardware or software is properly installed. If this is a new installation, ask your hardware or software manufacturer for any windows updates you might need.

If problems continue, disable or remove any newly installed hardware or software. Disable BIOS memory options such as caching or shadowing. If you need to use Safe Mode to remove or disable components, restart your computer, press F8 to select Advanced startup options, and then select Safe Mode.

Technical information:

*** STOP: 0x00000050 (0x800005F2, 0x00000000, 0x804E83C8, 0x00000000)

Beginning dump of physical memory
Physical memory dump complete.

Contact your system administrator or technical support group for further assistance.

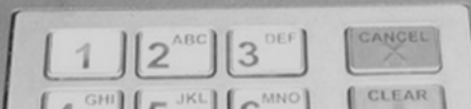

The development of a

family of software systems

differs from the development of

a **single** software system

THANKS CAPTAIN
OBVIOUS



« The development of a **family** of software systems differs from the development of a **single** software system »

Reuse

Commonality

Customization

Variability

Automation



Assembly Line and Mass Customization



Reuse and Mass Customization

A man with dark hair, wearing a dark sweater, sits at a dark desk with his hands pressed against his head, eyes closed in a state of stress or frustration. On the desk in front of him is a white sheet of paper with a pen lying on it. To the left of the paper is a glass of red wine, and to the right is a crumpled piece of white paper. Another crumpled piece of paper is on the desk to the left of the man. The background is a plain wall with a blue and white light gradient.

Starting from scratch?

An aerial view of a massive aircraft manufacturing plant. The facility is filled with several large commercial aircraft in various stages of assembly. In the foreground, a large white aircraft with a blue tail is being worked on, surrounded by extensive scaffolding. Other planes are visible in the background, some with their wings or fuselages partially assembled. The floor is a complex network of walkways, workstations, and equipment. The high ceiling is supported by a dense grid of steel beams and is lit with numerous overhead lights. The overall scene conveys a sense of large-scale industrial production.

You cannot start from scratch

“a set of software- intensive systems that share a common, managed set of features satisfying the specific needs of a particular market segment or mission and that are developed from a common set of core assets in a prescribed way” [Clements et al., 2001]

Software Product Lines

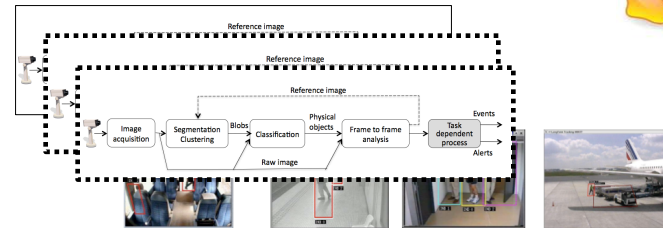
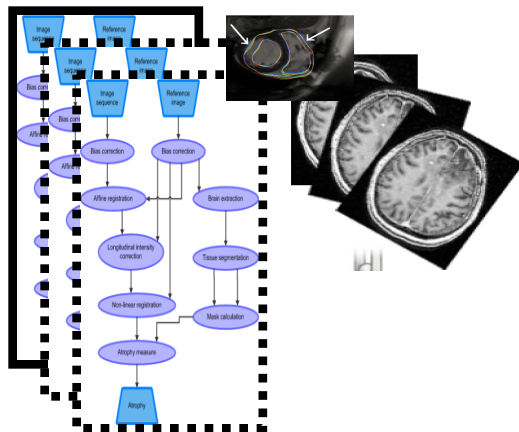

Software Product-Line Engineering

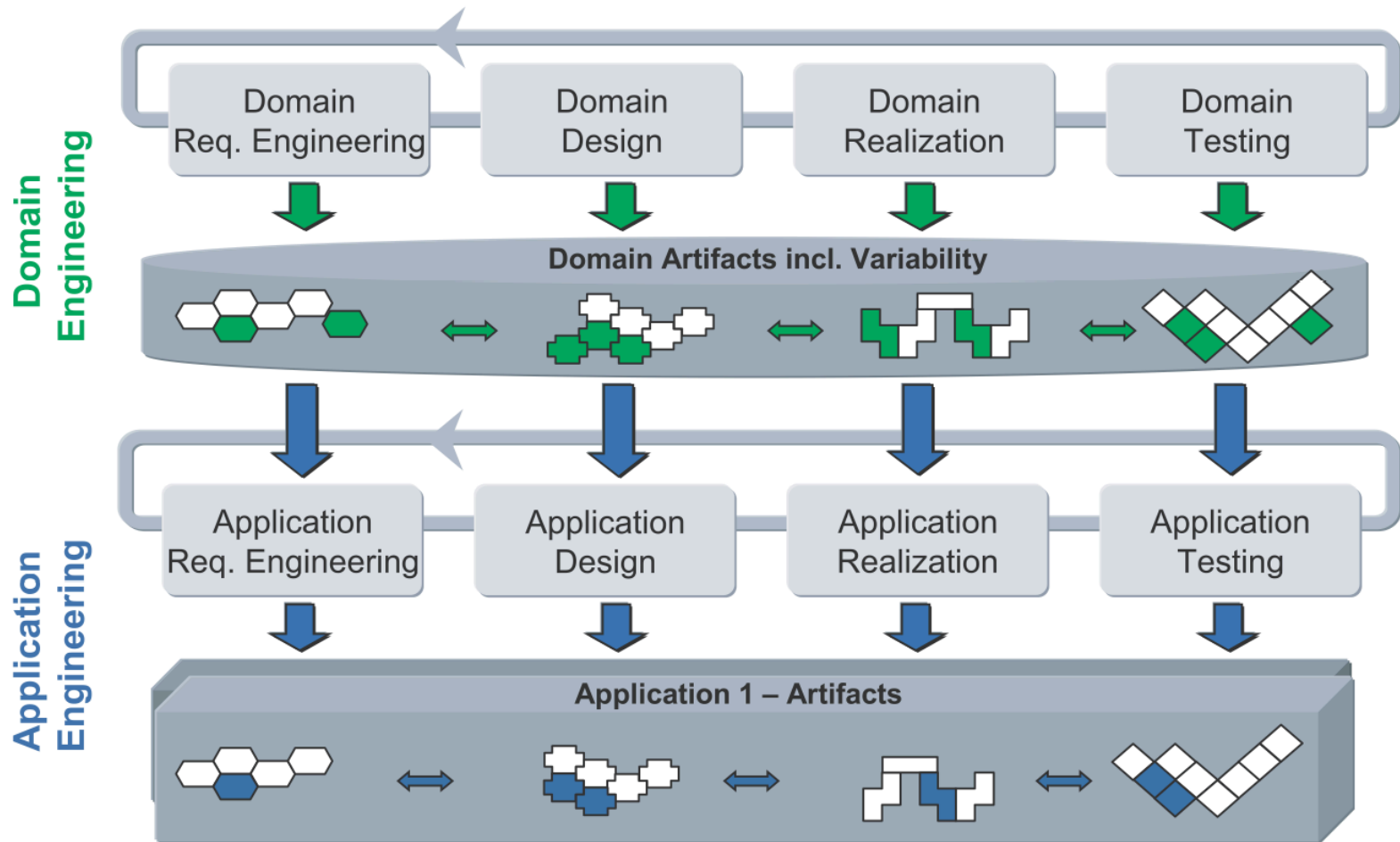

Mapping: an example

```
class Graph {  
    Vector nv = new Vector(); Vector ev = new Vector();  
    Edge add(Node n, Node m) {  
        Edge e = new Edge(n, m);  
        nv.add(n); nv.add(m); ev.add(e);  
        e.weight = new Weight();  
        return e;  
    }  
    Edge add(Node n, Node m, Weight w)  
        Edge e = new Edge(n, m);  
        nv.add(n); nv.add(m); ev.add(e);  
        e.weight = w; return e;  
    }  
    void print() {  
        for(int i = 0; i < ev.size(); i++) {  
            ((Edge)ev.get(i)).print();  
        }  
    }  
}
```

```
class Node {  
    int id = 0;  
    Color color = new Color();  
    void print() {  
        Color.setDisplayColor(color);  
        System.out.print(id);  
    }  
}
```

```
class Edge {  
    Node a, b;  
    Color color = new Color();  
    Weight weight;=  
    Edge(Node _a, Node _b) { a = _a; b = _b; }  
    void print() {  
        Color.setDisplayColor(color);  
        a.print(); b.print();  
        weight.print();  
    }  
}
```

```
class Color {  
    static void setDisplayColor(Color c) { ... }  
}
```

```
class Weight { void print() { ... } }
```

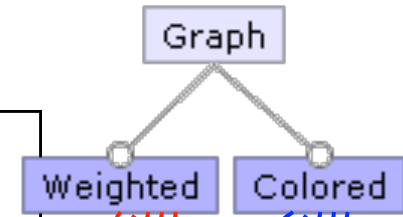

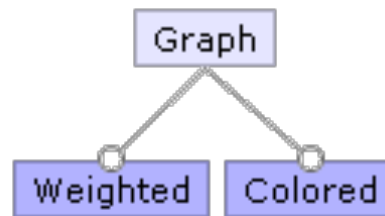

```

class Graph {
  Vector nv = new Vector(); Vector ev = new Vector();
  Edge add(Node n, Node m) {
    Edge e = new Edge(n, m);
    nv.add(n); nv.add(m); ev.add(e);
    /*if[WEIGHT]*/
    e.weight = new Weight();
    /*end[WEIGHT]*/
    return e;
  }
  /*if[WEIGHT]*/
  Edge add(Node n, Node m, Weight w)
  Edge e = new Edge(n, m);
  nv.add(n); nv.add(m); ev.add(e);
  e.weight = w; return e;
}
/*end[WEIGHT]*/
void print() {
  for(int i = 0; i < ev.size(); i++) {
    ((Edge)ev.get(i)).print();
  }
}
}

```

```

/*if[WEIGHT]*/
class Weight { void print() { ... } }
/*end[WEIGHT]*/

```

```

class Edge {
  Node a, b;
  /*if[COLOR]*/
  Color color = new Color();
  /*end[COLOR]*/
  /*if[WEIGHT]*/
  Weight weight;
  /*end[WEIGHT]*/
  Edge(Node _a, Node _b) { a = _a; b = _b; }
  void print() {
    /*if[COLOR]*/
    Color.setDisplayColor(color);
    /*end[COLOR]*/
    a.print(); b.print();
    /*if[WEIGHT]*/
    weight.print();
    /*end[WEIGHT]*/
  }
}

```

```

/*if[COLOR]*/
class Color {
  static void setDisplayColor(Color c) { ... }
}
/*end[COLOR]*/

```

```

class Node {
  int id = 0;
  /*if[COLOR]*/

```

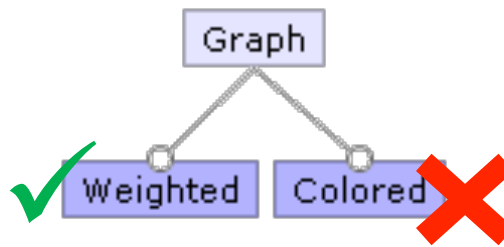

```

class Graph {
  Vector nv = new Vector(); Vector ev = new Vector();
  Edge add(Node n, Node m) {
    Edge e = new Edge(n, m);
    nv.add(n); nv.add(m); ev.add(e);
    e.weight = new Weight();
    return e;
  }
  Edge add(Node n, Node m, Weight w)
    Edge e = new Edge(n, m);
    nv.add(n); nv.add(m); ev.add(e);
    e.weight = w; return e;
  }
  void print() {
    for(int i = 0; i < ev.size(); i++) {
      ((Edge)ev.get(i)).print();
    }
  }
}
  
```

```

class Edge {
  Node a, b;
  Weight weight;
  Edge(Node _a, Node _b) { a = _a; b = _b; }
  void print() {
    a.print(); b.print();
    weight.print();
  }
}
  
```

```

class Node {
  int id = 0;
  void print() {
    System.out.print(id);
  }
}
  
```

```

class Weight { void print() { ... } }
  
```

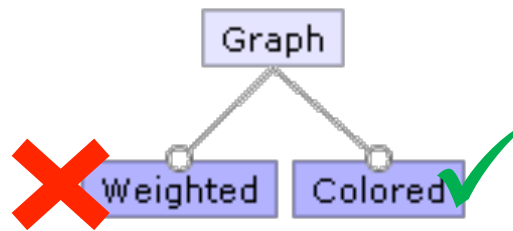

```

class Graph {
  Vector nv = new Vector(); Vector ev = new Vector();
  Edge add(Node n, Node m) {
    Edge e = new Edge(n, m);
    nv.add(n); nv.add(m); ev.add(e);
  }
  return e;
}
void print() {
  for(int i = 0; i < ev.size(); i++) {
    ((Edge)ev.get(i)).print();
  }
}
}

```

```

class Edge {
  Node a, b;
  Color color = new Color();
  Edge(Node _a, Node _b) { a = _a; b = _b; }
  void print() {
    Color.setDisplayColor(color);
    a.print(); b.print();
  }
}

```

```

class Color {
  static void setDisplayColor(Color c) { ... }
}

```

```

class Node {
  int id = 0;
  Color color = new Color();
  void print() {
    Color.setDisplayColor(color);
    System.out.print(id);
  }
}

```

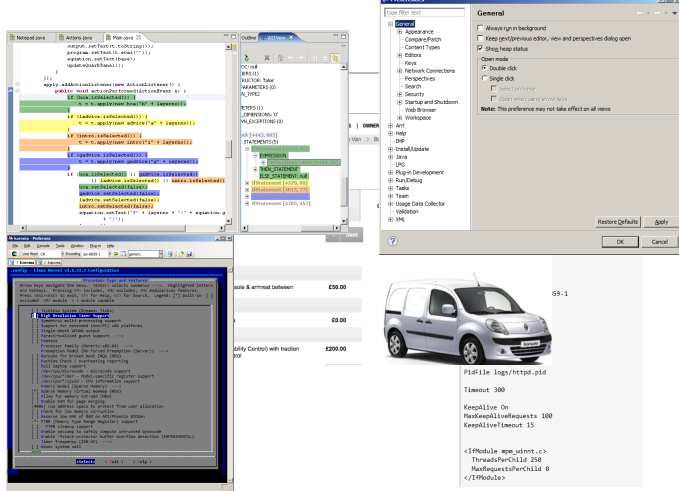

variantes de code (e.g., Java ou C)
 variantes d'interface utilisateur
 variantes de séquence vidéo
 variantes de langages
 variantes de **modèles**

...

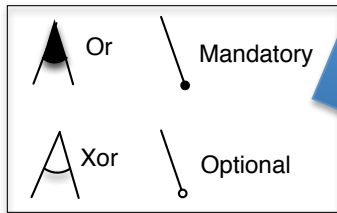
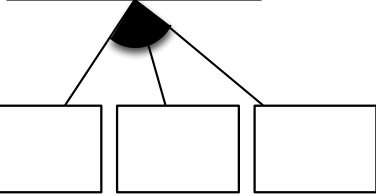
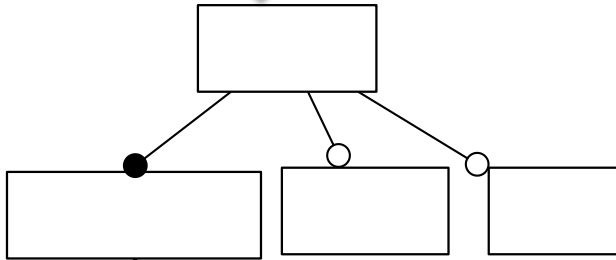
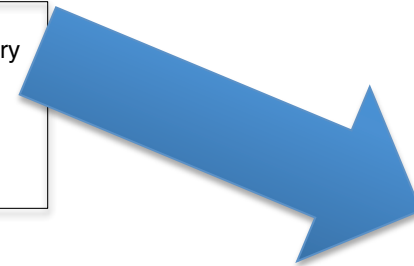
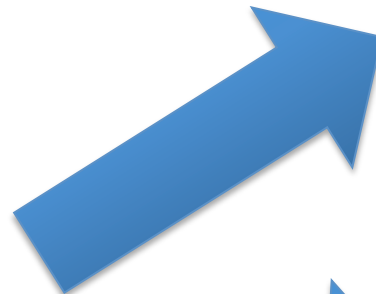

not, and, or, implies

Feature Models

Feature-based Model Templates

Presence conditions:

- true 
- WishLists  1
- SendWishList  2
- Registration  3

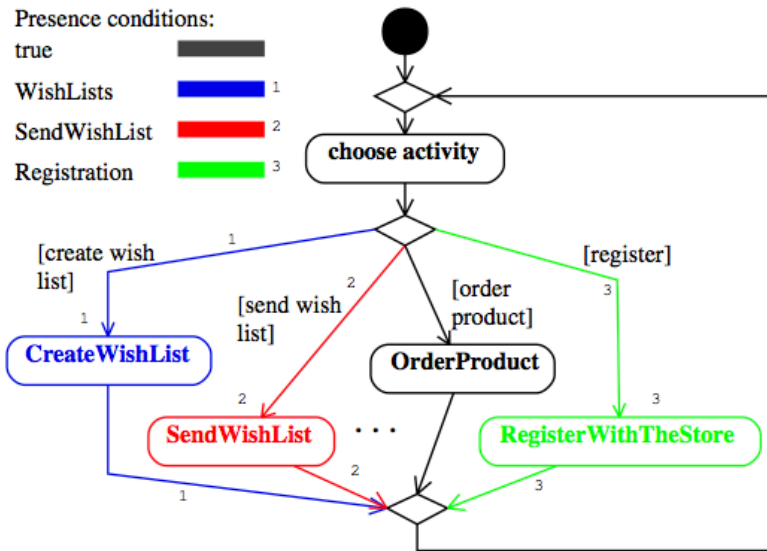

(a) Storefront template

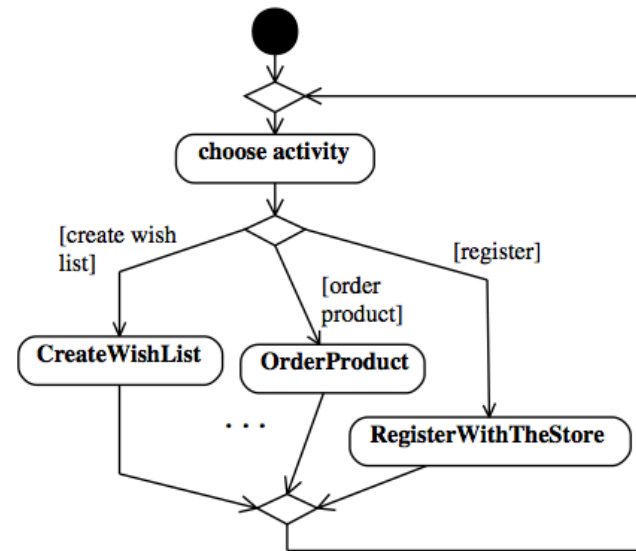

(b) Storefront instance

Approach

Presence conditions:

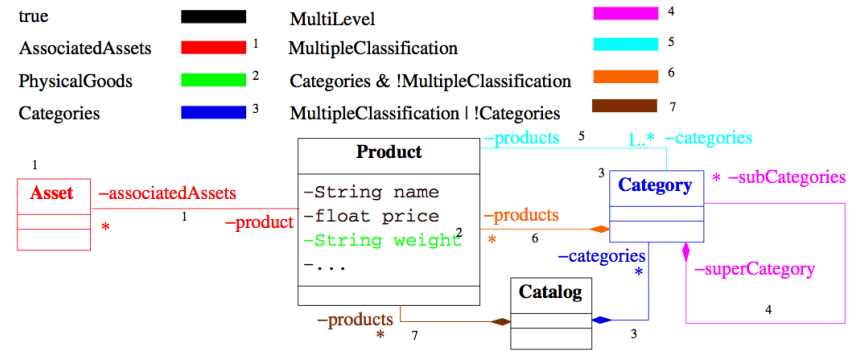

Refers to features through annotations

Feature model

Manual configuration process

Feature configuration

Features/Options

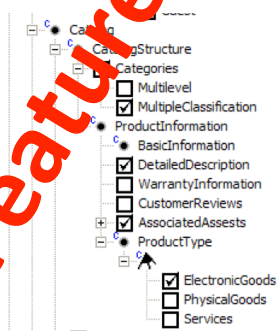

Model template
expressed in target notation and annotated with presence conditions and meta-expressions

Automatic template instantiation







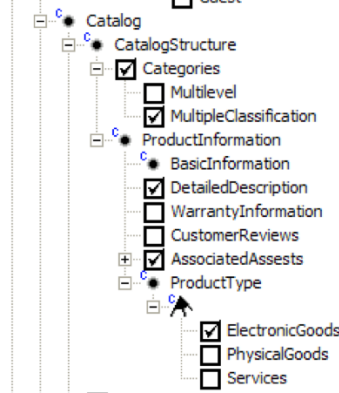

- Evaluation of presence conditions and meta-expressions
- Element removal
- Post-processing

Template instance

Product Model



Presence conditions:

true		MultiLevel		4	
AssociatedAssets		1	MultipleClassification		5
PhysicalGoods		2	Categories & !MultipleClassification		6
Categories		3	MultipleClassification !Categories		7

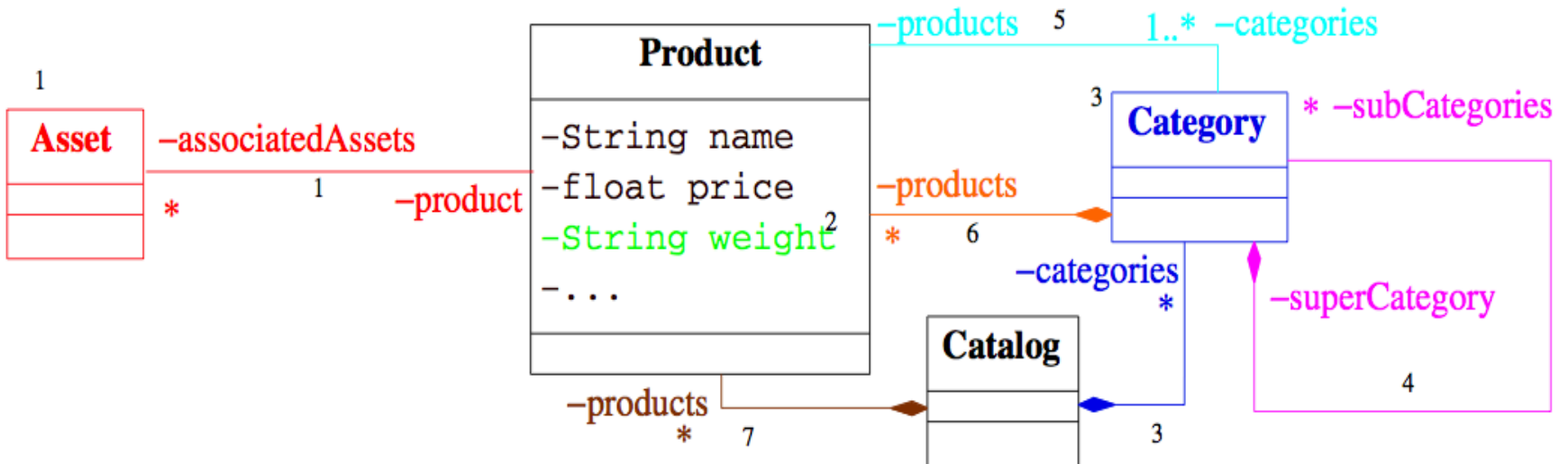

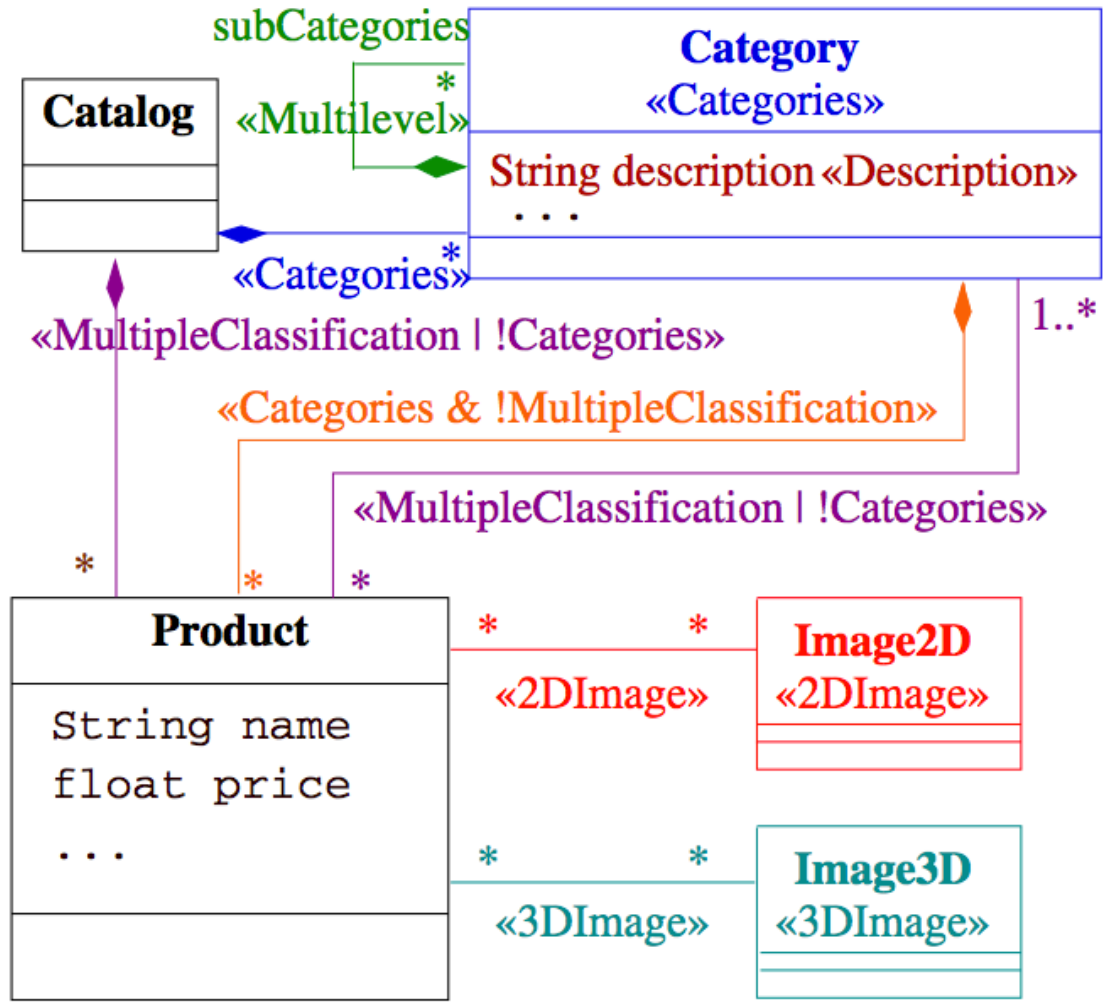
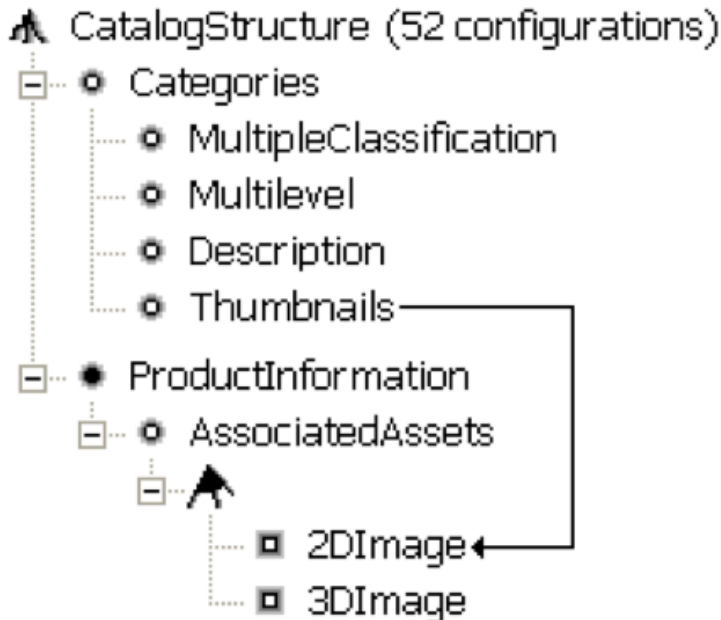

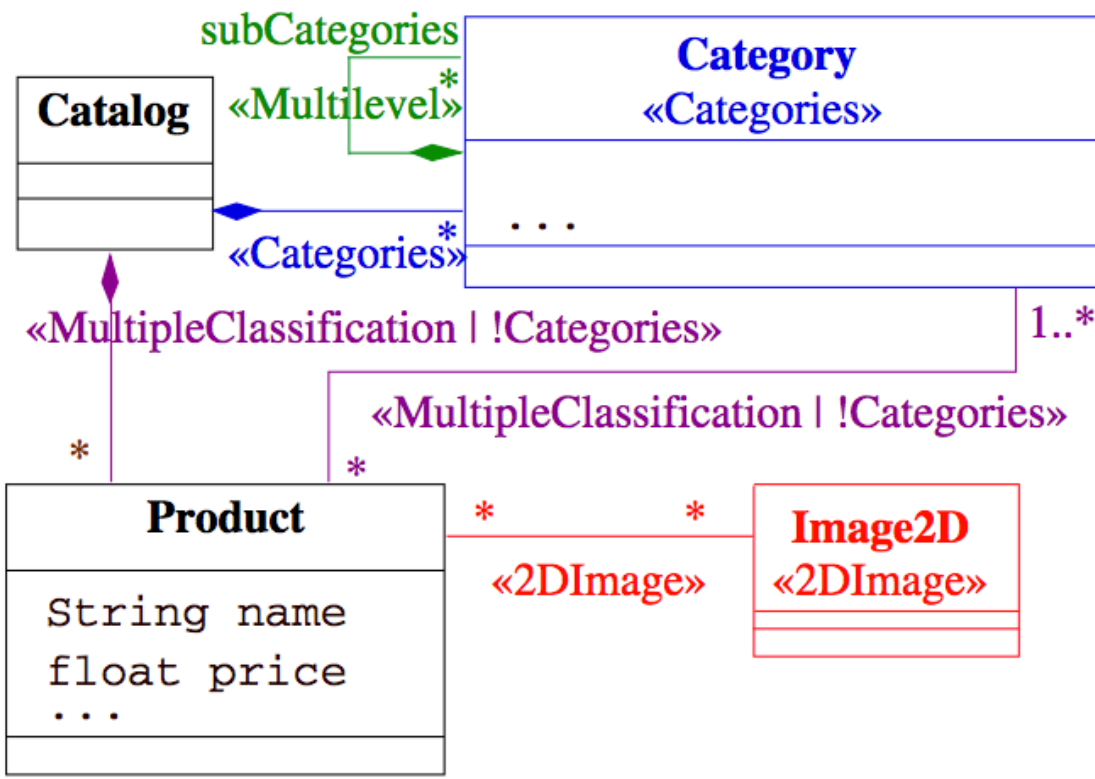
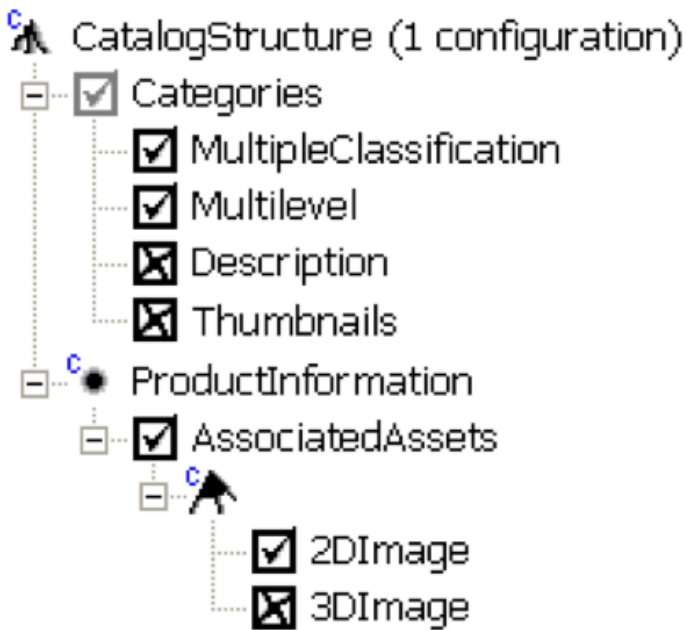

Ooops

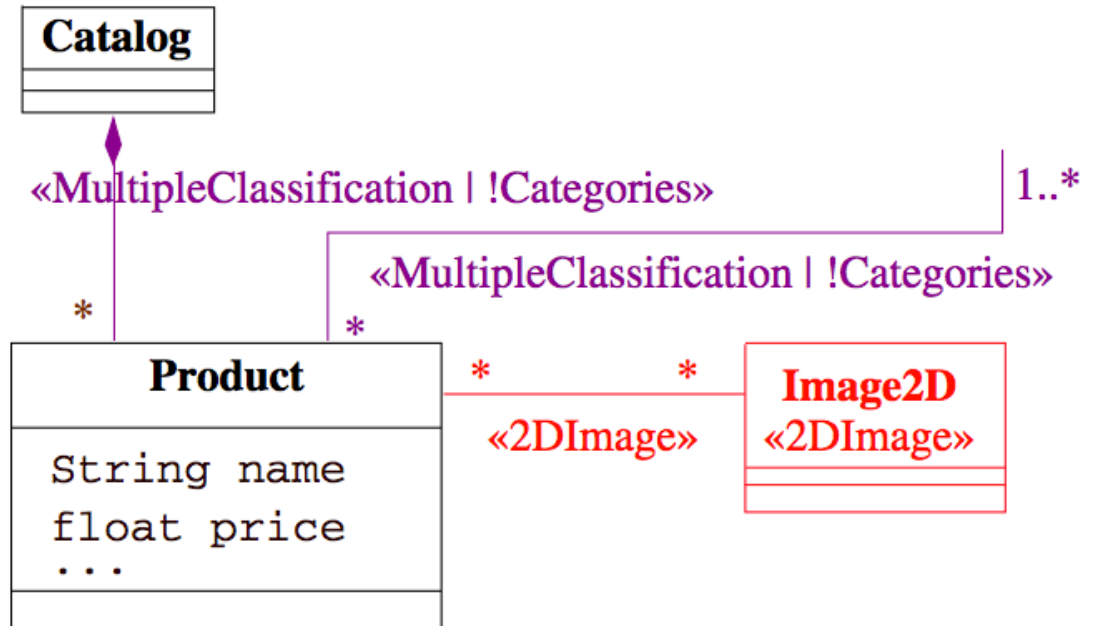
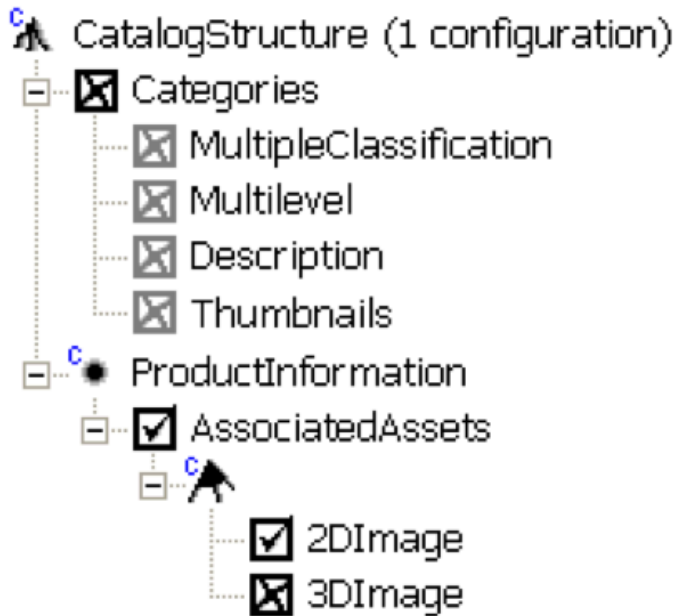

Domain Engineering

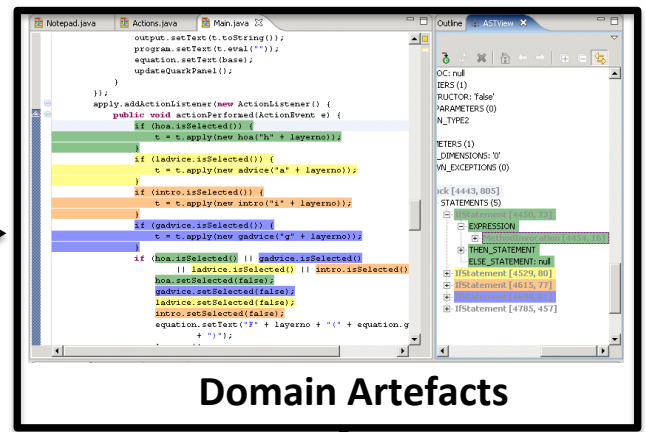
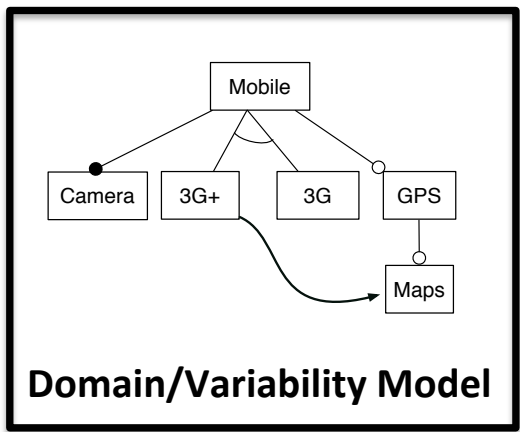

Application Engineering

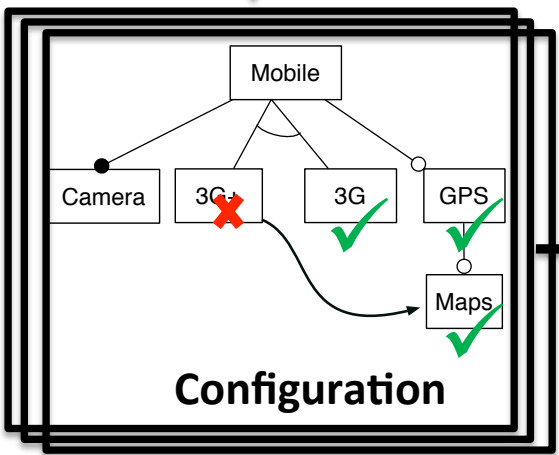

« the investments required to develop the reusable artifacts during domain engineering, are outweighed by the benefits of deriving the individual products during application engineering »

Jan Bosch et al. (2004)

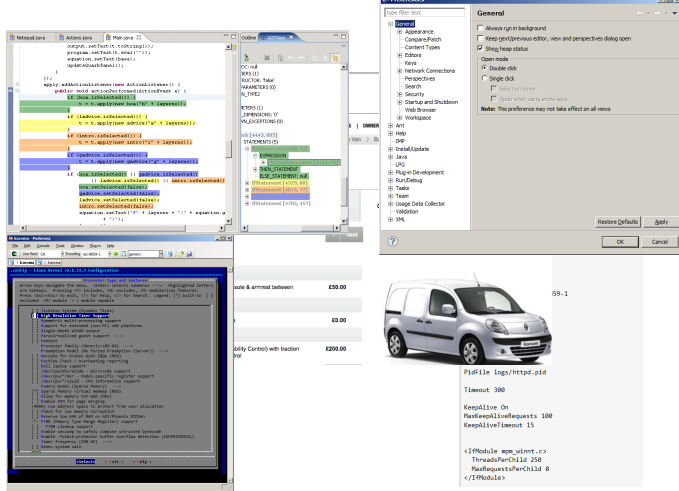

variantes de code (e.g., Java ou C)
 variantes d'interface utilisateur
 variantes de séquence vidéo
 variantes de langages
 variantes de modèles

...

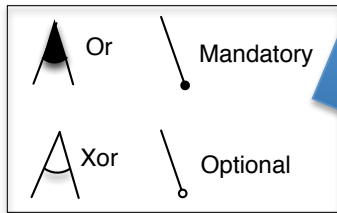
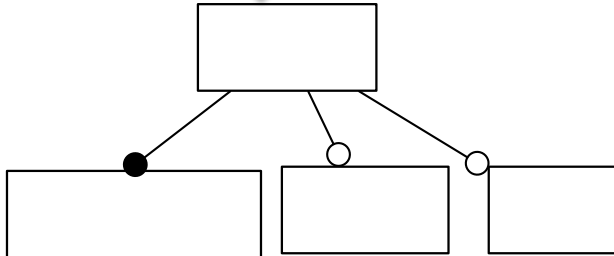
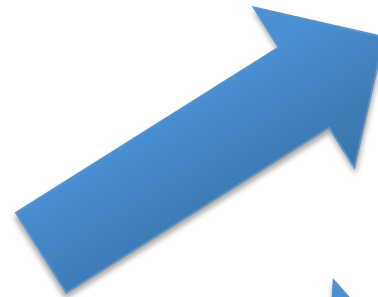

not, and, or, implies

Feature Models

Software Product Line and Variability Engineering

A revisit of your cursus

What is new?

Family vs single systems

Focus on **reuse**

Domain engineering

Factoring out **commonality**

Managing **variability**

« variability »

Is it really new?

Parameter

```
Administrator: C:\Windows\system32\cmd.exe
C:\Users\kaestner.INFORMATIK.000>dir /?
Displays a list of files and subdirectories in a directory.

DIR [drive:][path][filename] [/A[[:]attributes]] [/B] [/C] [/D] [/L] [/N]
  [/O[[:]sortorder]] [/P] [/Q] [/R] [/S] [/T[[:]timefield]] [/W] [/X] [/4]

[drive:][path][filename]
    Specifies drive, directory, and/or files to list.

/A          Displays files with specified attributes.
attributes  D Directories          R Read-only files
             H Hidden files        A Files ready for archiving
             S System files        I Not content indexed files
             L Reparse Points      - Prefix meaning not

/B          Uses bare format (no heading information or summary).
/C          Display the thousand separator in file sizes. This is the
             default. Use /-C to disable display of separator.
/D          Same as wide but files are list sorted by column.
/L          Uses lowercase.
/N          New long list format where filenames are on the far right.
/O          List by files in sorted order.
sortorder   N By name (alphabetic)   S By size (smallest first)
             E By extension (alphabetic) D By date/time (oldest first)
             G Group directories first - Prefix to reverse order

/P          Pauses after each screenful of information.
```

Parameter `-i` in `grep`

```
1  int match_icase;
2
3  int main (int argc, char **argv)
4  {
5      [...]
6      while ((opt = get_nondigit_option (argc, argv, &default_c
7          switch (opt)
8          {
9              [...]
10             case 'i':
11                 match_icase = 1;
12                 break;
13             }
14     }
15
16
17     static const char *
18     print_line_middle (const char *beg, const char *lim,
19         const char *line_color, const char *match_color)
20     {
21         [...]
22         if (match_icase)
23         {
24             ibeg = buf = (char *) xmalloc(i);
25             while (--i >= 0)
26                 buf[i] = tolower(beg[i]);
27         }
```

Global configuration

```
class Config {
    public static boolean isLogging = false;
    public static boolean isWindows = false;
    public static boolean isLinux = true;
}
class Main {
    public void foo() {
        if (isLogging)
            log(„running foo()“);
        if (isWindows)
            callWindowsMethod();
        else if (isLinux)
            callLinuxMethod();
        else
            throw RuntimeException();
    }
}
```

Configuration

httpd.conf -- win32 Apache Building a Web Server, for Windows

```
Listen 80
ServerRoot "/www/Apache2"
DocumentRoot "/www/webroot"

ServerName localhost:80
ServerAdmin admin@localhost

ServerSignature On
ServerTokens Full
```

```
DefaultType text/plain
AddDefaultCharset ISO-8859-1
```

```
UseCanonicalName Off
```

```
HostnameLookups Off
```

```
ErrorLog logs/error.log
LogLevel error
```

```
PidFile logs/httpd.pid
```

```
Timeout 300
```

```
KeepAlive On
MaxKeepAliveRequests 100
```

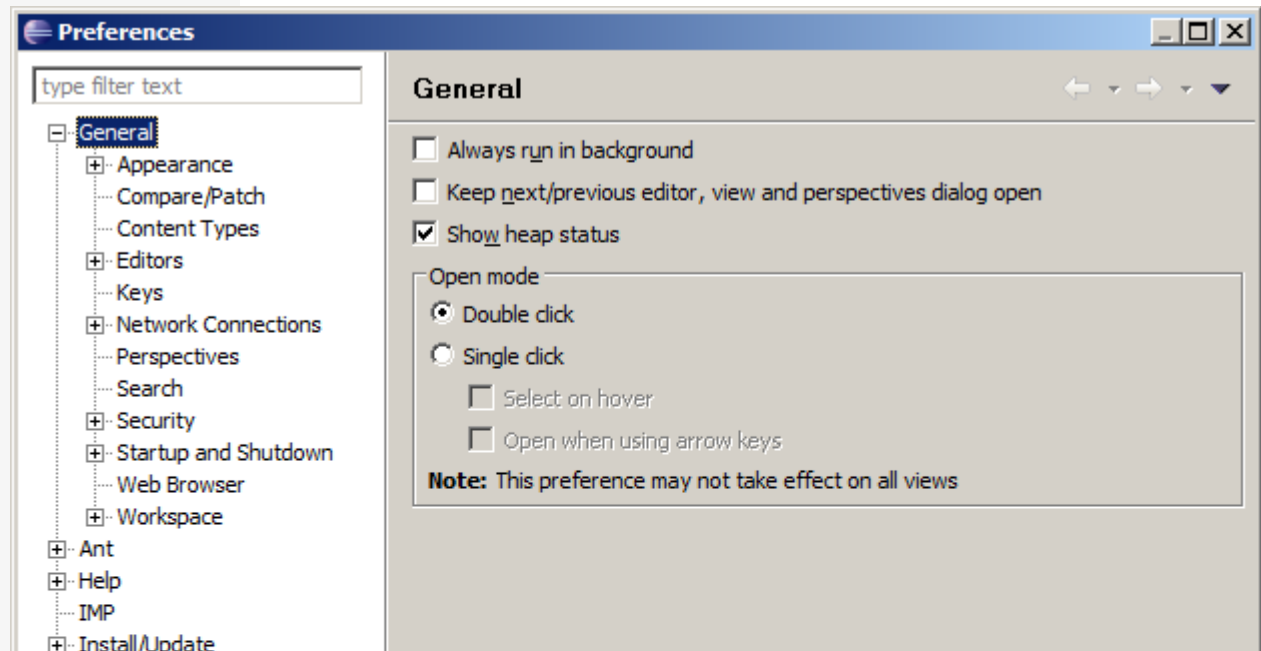
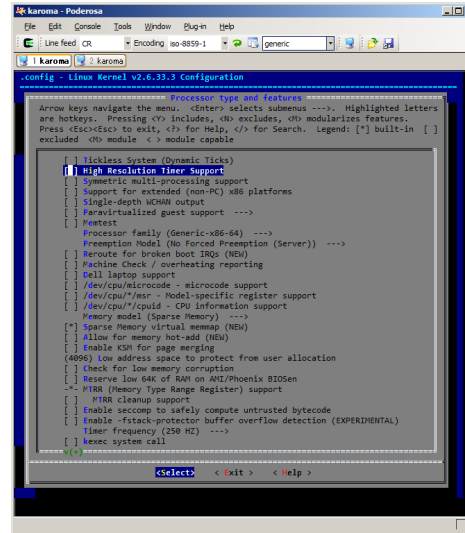

Conditional compilation

#ifdef (Berkeley DB)

```
static int __rep_queue_filedone(dbenv, rep, rfp)
    DB_ENV *dbenv;
    REP *rep;
    __rep_fileinfo_args *rfp; {
#ifndef HAVE_QUEUE
    COMPQUIET(rep, NULL);
    COMPQUIET(rfp, NULL);
    return (__db_no_queue_am(dbenv));
#else
    db_pgno_t first, last;
    u_int32_t flags;
    int empty, ret, t_ret;
#ifdef DIAGNOSTIC
    DB_MSGBUF mb;
#endif
    // over 100 lines of additional code
}
#endif
```

Intentional Code Cloning

~ Copy & Paste

Code Cloning (example, Linux driver)

cyberstorm.c

```
....
static void dma_dump_state(struct NCR_ESP *esp)
{
    ESPLOG(("esp%d: dma -- cond_reg<%02x>\n",
           esp->esp_id, ((struct cyber_dma_registers *)
                        (esp->dregs))->cond_reg));
    ESPLOG(("intreq:<%04x>, intena:<%04x>\n",
           custom.intreqr, custom.intenar));
}

static void dma_init_read(struct NCR_ESP *esp, __u32 addr, int
length)
{
    struct cyber_dma_registers *dregs =
        (struct cyber_dma_registers *) esp->dregs;

    cache_clear(addr, length);

    addr &= ~(1);
    dregs->dma_addr0 = (addr >> 24) & 0xff;
    dregs->dma_addr1 = (addr >> 16) & 0xff;
    dregs->dma_addr2 = (addr >> 8) & 0xff;
    dregs->dma_addr3 = (addr >> 0) & 0xff;
    ctrl_data &= ~(CYBER_DMA_WRITE);
}
.....
```

cyberstormII.c

```
....
static void dma_dump_state(struct NCR_ESP *esp)
{
    ESPLOG(("esp%d: dma -- cond_reg<%02x>\n",
           esp->esp_id, ((struct cyberII_dma_registers *)
                        (esp->dregs))->cond_reg));
    ESPLOG(("intreq:<%04x>, intena:<%04x>\n",
           custom.intreqr, custom.intenar));
}

static void dma_init_read(struct NCR_ESP *esp, __u32 addr, int
length)
{
    struct cyberII_dma_registers *dregs =
        (struct cyberII_dma_registers *) esp->dregs;

    cache_clear(addr, length);

    addr &= ~(1);
    dregs->dma_addr0 = (addr >> 24) & 0xff;
    dregs->dma_addr1 = (addr >> 16) & 0xff;
    dregs->dma_addr2 = (addr >> 8) & 0xff;
    dregs->dma_addr3 = (addr >> 0) & 0xff;
}
.....
```

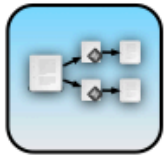

Replicate & Specialize



Clone to reuse and adapt existing solutions

- + Less effort needed
- Long-term cost outweighs short-term benefit
- ~ Cost of refactoring rises over time



Platform Variations



Clone existing code and fix low level platform interaction

- + Avoid complexity of virtualization layer
- Hard to propagate bug fixes
- ~ Ensure consistent behavior of all clones



Hardware Variations

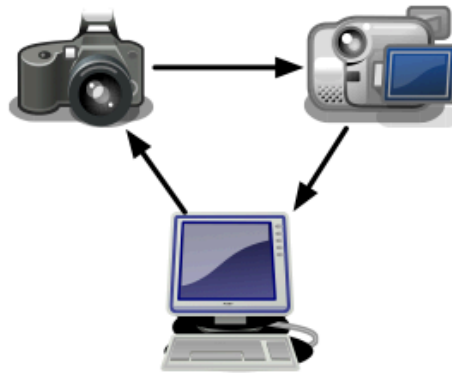

Clone existing driver

- + No risk of changing existing driver
- Code growth
- ~ Dead code can creep into system

Inheritance (OOP)

Base Class encapsulate commonalities

Derive classes specialize peculiarities

Generic Programming

C++ template

```
template <typename T>
T max(T x, T y)
{
    return x < y ? y : x;
}
```

Generics in Java

```
public interface List<E> {
    void add(E x);
    Iterator<E> iterator();
}
public interface Iterator<E> {
    E next();
    boolean hasNext();
}
```

Design Patterns

(more details in the next course)

Template Method

Factory

Strategy

Decorator

....

Template Method

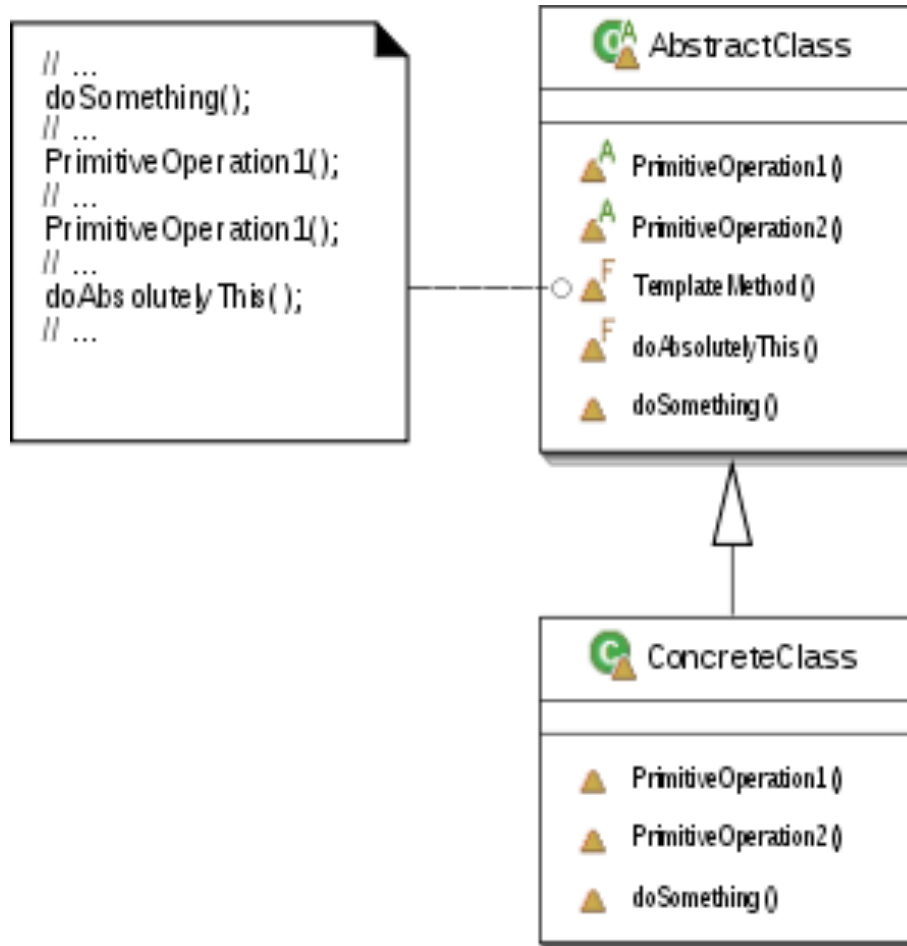

The decision model

- The Abstract Factory Design Pattern
 - [Gamma et al 95]

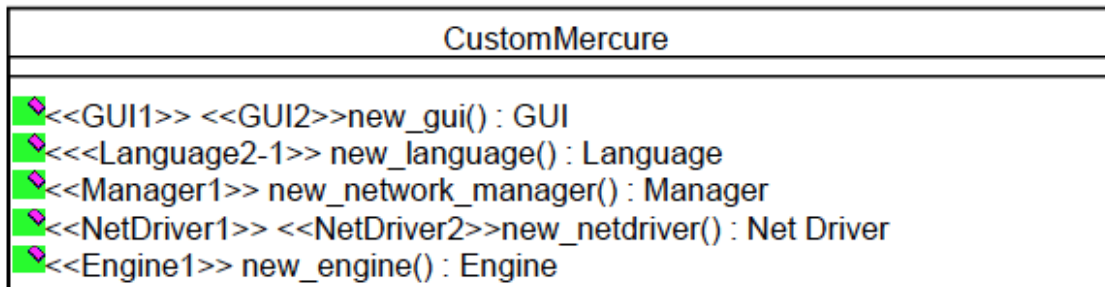
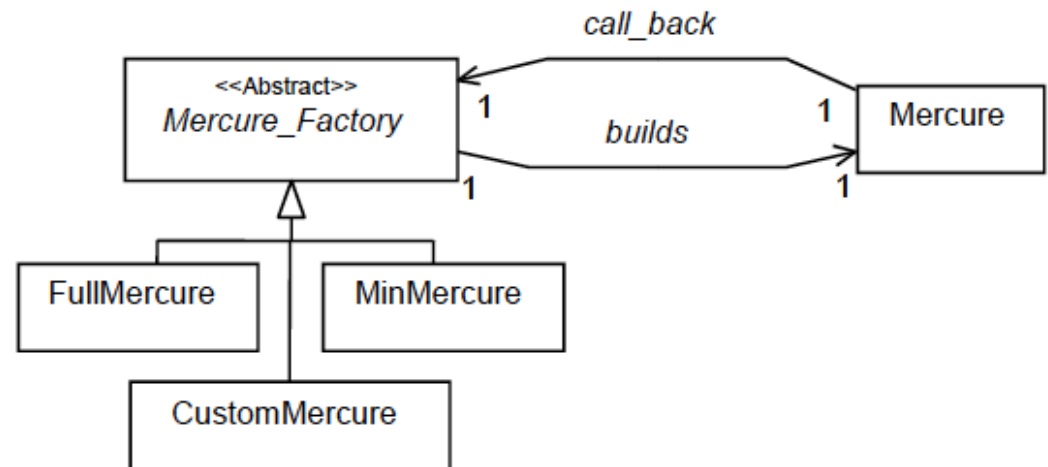
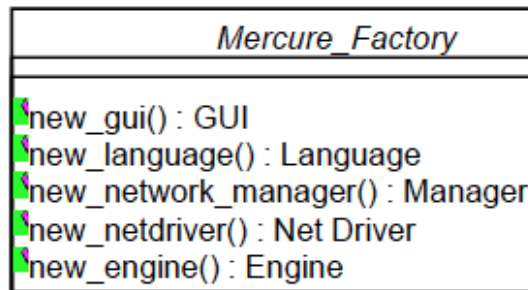

API

Framework

Plugin-based systems

httpd.conf -- win32 Apache

Building a Web Server, for Windows

```
Listen 80
ServerRoot "/www/Apache2"
DocumentRoot "/www/webroot"

ServerName localhost:80
ServerAdmin admin@localhost

ServerSignature On
ServerTokens Full

DefaultType text/plain
AddDefaultCharset ISO-8859-1
```

UseCanonicalName Off

HostnameLookups Off

ErrorLog logs/error.log
LogLevel error

PidFile logs/httpd.pid

Timeout 300

KeepAlive On
MaxKeepAliveRequests 100
KeepAliveTimeout 15

```
<IfModule mpm_winnt.c>
  ThreadsPerChild 250
  MaxRequestsPerChild 0
</IfModule>
```

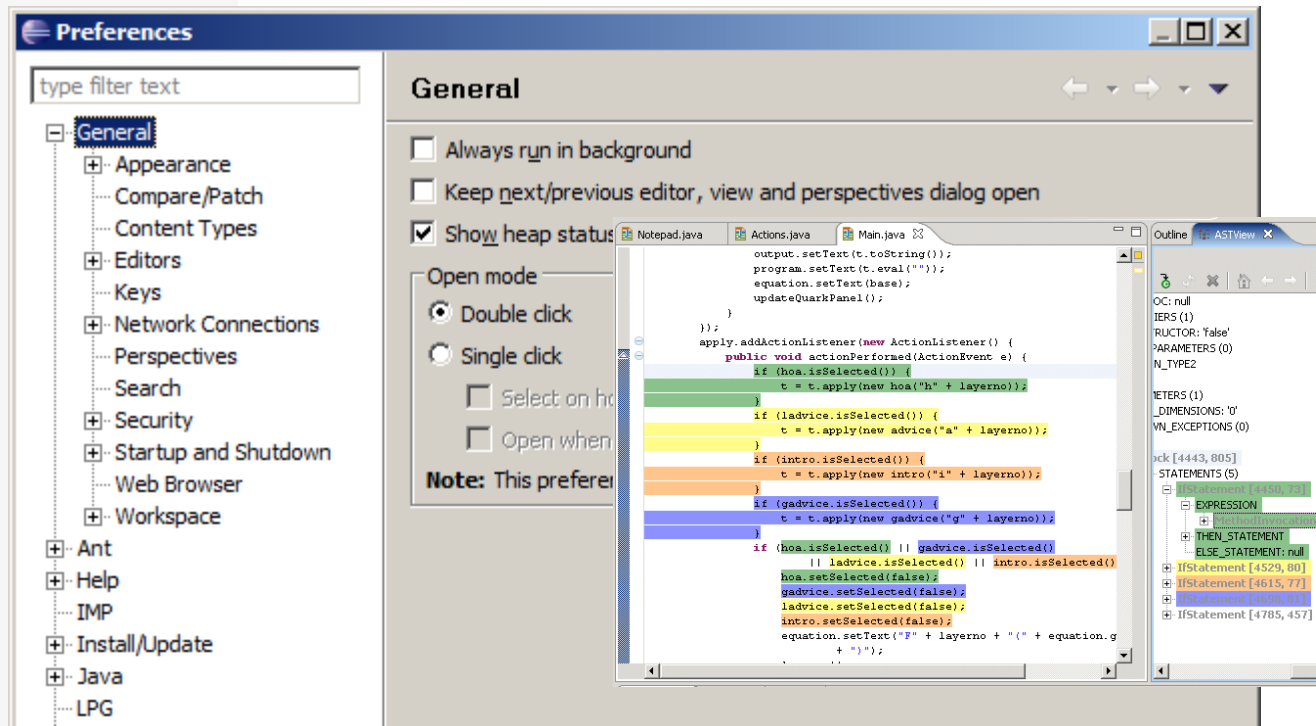
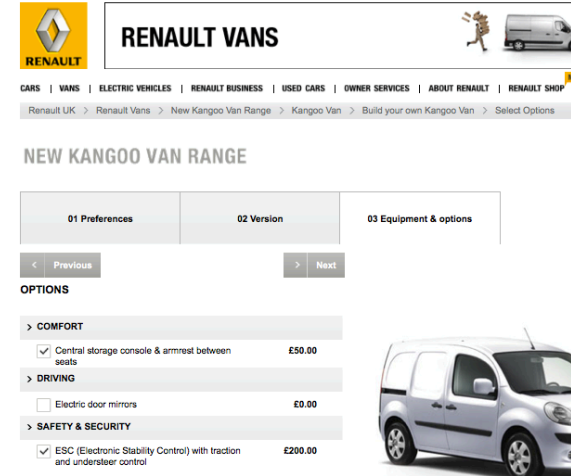
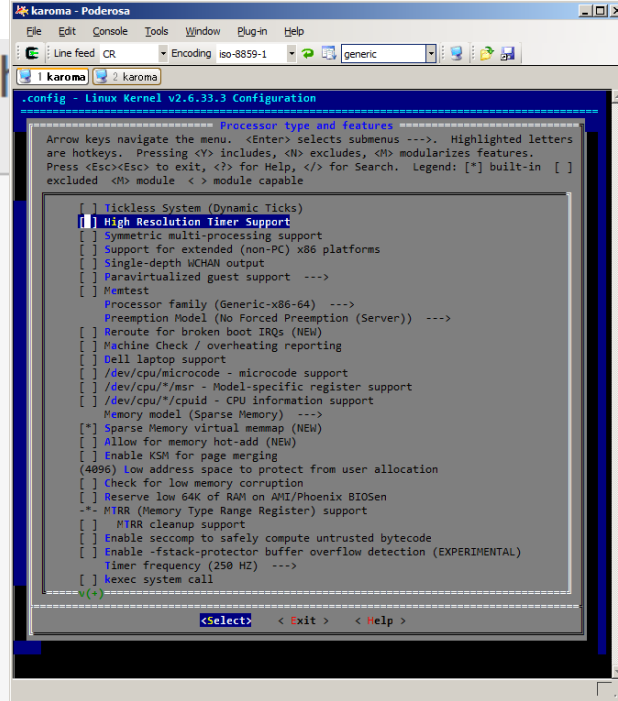

Feature Models

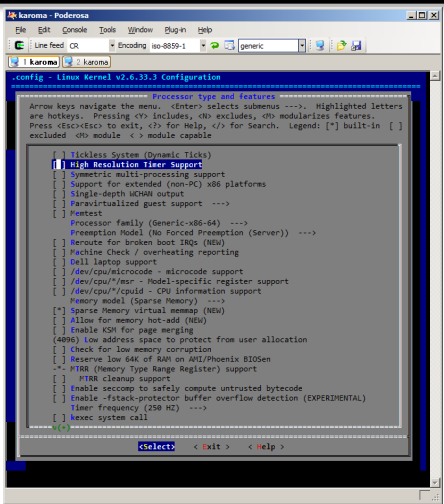

Variability Model

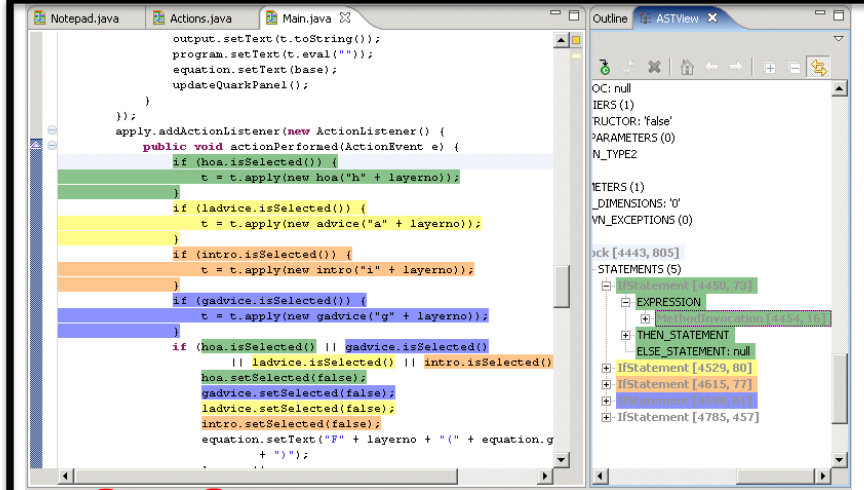

Main artifacts (e.g., source code)

Modeling variability is crucial

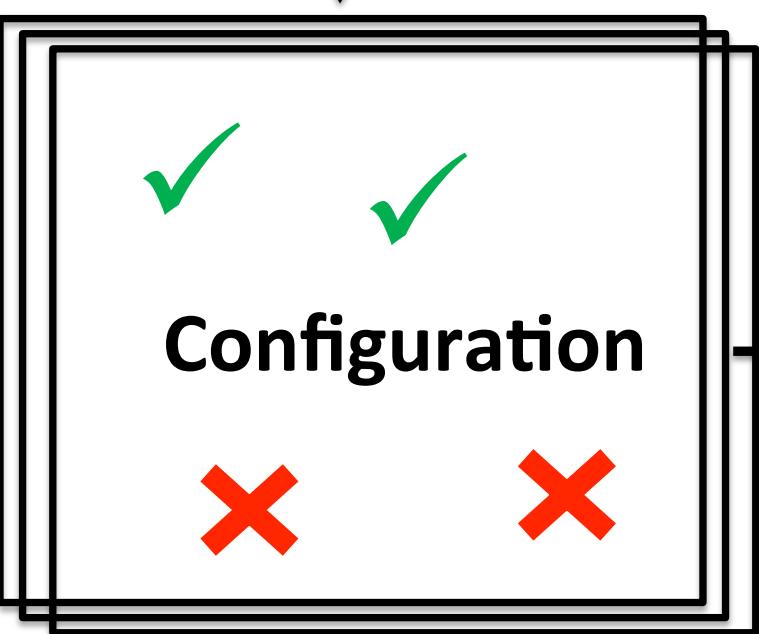

Unused flexibility





Illegal variant

Feature Model

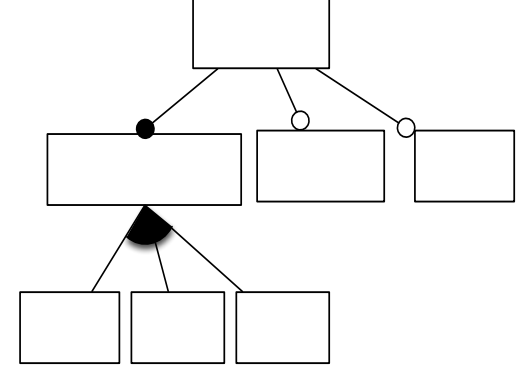

not, and, or, implies

Communicative

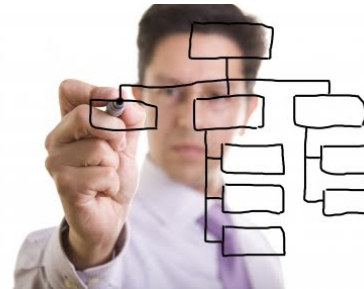

Analytic

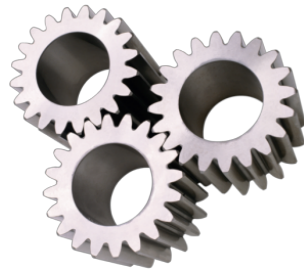

Generative

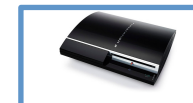
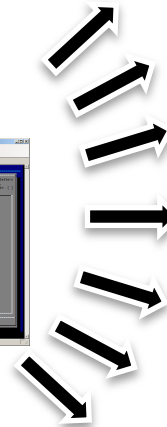
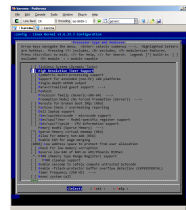



R8 Spyder 5.2 FSI quattro R tronic

Prix total

171.216,00 EUR

Prix de base **170.490,00 EUR**

Équipements optionnels **726,00 EUR**

- ▶ Informations détaillées
- ▶ Entrez l'Audi Code **8**
- ▶ Générer un PDF
- ▶ Nouvelle configuration

[+] Plein écran / Dimensions ▶ Fermer la capote Habitacle Tableau de bord

Packs

Aucun pack n'est proposé pour ce modèle.

Couleurs

Blanc Ibis

Noir

Prix: 0,00 EUR



Couleurs métallisées à partir de 0,00 EUR



Couleurs à effet perlé à partir de 0,00 EUR



Couleurs personnalisées Audi exclusive

Audi exclusive

Couleur capote

Noir

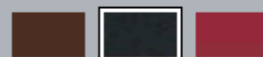

Jantes

4 Jantes alu 5 BRANCHES ROTOR finition titane 8,5 x 19 à l'avant, 11 x 19 à l'arrière. Pneus 235/35 R19 à l'avant et 305 /30 R19 à l'arrière
Prix: 726,00 EUR

19" à partir de 0,00 EUR





R8 Spyder 5.2 FSI quattro R tronic

Prix total

185.899,35 EUR

Prix de base

170.490,00 EUR

Équipements optionnels

15.409,35 EUR

- ▶ Informations détaillées
- ▶ Entrez l'Audi Code
- ▶ Générer un PDF
- ▶ Nouvelle configuration

[+] Plein écran / Dimensions Vue extérieure Tableau de bord

- ▶ Packs d'équipements
- ▶ Extérieur
- ▶ Jantes & pneumatiques
- ▶ Intérieur
- ▶ Volants
- ▶ Sièges
- Sécurité & technique**
- ▶ Infotainment

- ▶ Châssis
- ▶ Freins
- Systèmes d'assistance**
- ▶ Autres

excludes

<input checked="" type="checkbox"/>	Régulateur de vitesse		320,65 EUR
<input type="checkbox"/>	Système d'aide au stationnement APS avant / arrière		931,70 EUR
<input type="checkbox"/>	Système d'aide au stationnement APS avant / arrière avec affichage dans l'écran MMI		1.373,35 EUR
<input checked="" type="checkbox"/>	Système d'aide au stationnement Advanced : APS avant et arrière et caméra arrière		1.790,80 EUR
<input type="checkbox"/>	Audi hill assist : assistance au démarrage en côte		Série

Réinitialiser la sélection

Attention:

Le prix peut varier en fonction du choix de moteur et des équipements.

Un aperç des équipements:

Mode expert

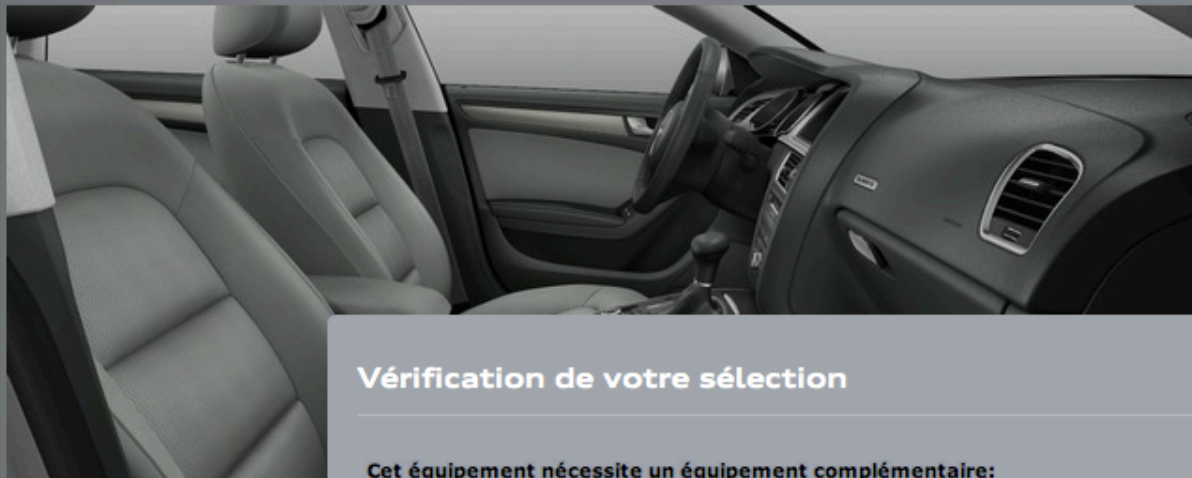

A5 Sportback 3.0 TDI quattro S tronic

Prix total

54.460,15 EUR

Prix de base

50.570,00 EUR

Équipements optionnels

3.890,15 EUR

- ▶ Informations détaillées
- ▶ Entrez l'Audi Code
- ▶ Nouvelle configuration

Vérification de votre sélection

Cet équipement nécessite un équipement complémentaire:

GPS Plus avec disque dur 2.934,25 EUR

Voici les équipements complémentaires possibles:

Ordinateur de bord en couleur avec programme efficiency 181,50 EUR

Remarque: uniquement sur les modèles avec système Start-Stop et uniquement disponible en combinaison avec l'autoradio Concert, l'autoradio Symphony ou un système de navigation

Pack Intenso Plus 3.100,00 EUR

Sans appareil de navigation

2.934,25 EUR

Série

[+] Plein écran / Dimensions

Packs d'équipements

- ▶ Extérieur
- ▶ Jantes & pneumatiques
- ▶ Intérieur
- ▶ Volants
- ▶ Sièges
- ▶ Sécurité & technique

Infotainment

Attention:

Le prix peut varier en fonction du choix de moteur et des équipements.

Un aperçu des équipements:

Mode expert

Réinitialiser la sélection

1 **Modèle**

2 **Moteur**

3 **Extérieur**

4 **Intérieur**

5 **Option**

6 **Votre Audi**

Francals

Suivant ▶

Feature Models (Background)

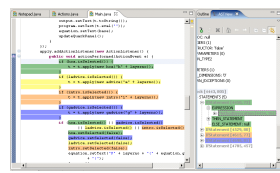
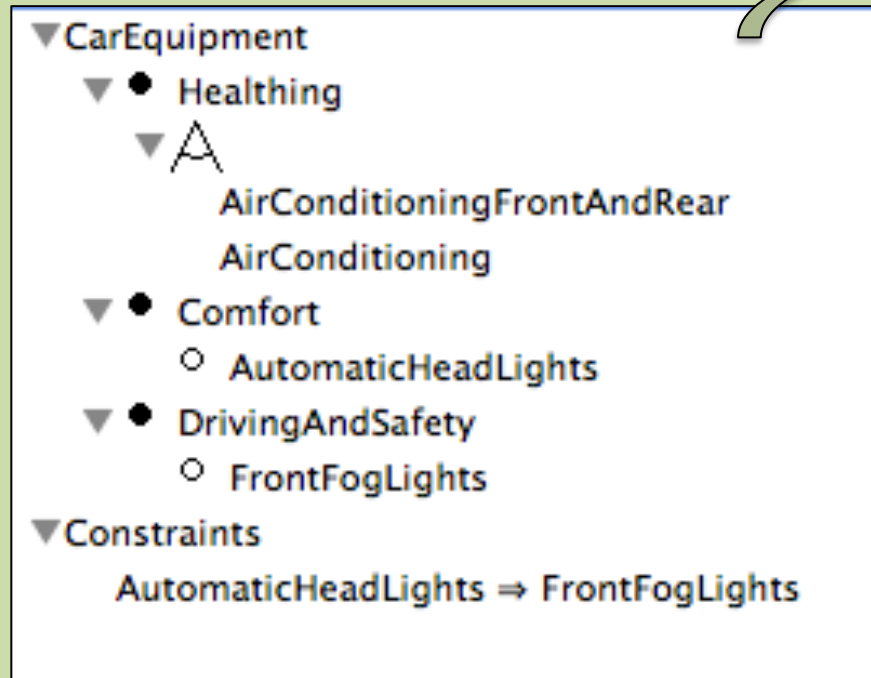

Hierarchy: rooted tree

Variability:

- mandatory,
- optional,
- Groups: exclusive or inclusive features
- Cross-tree constraints

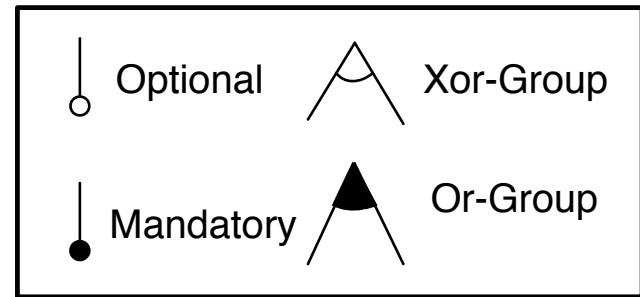

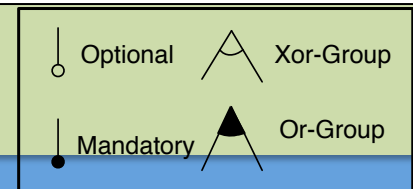
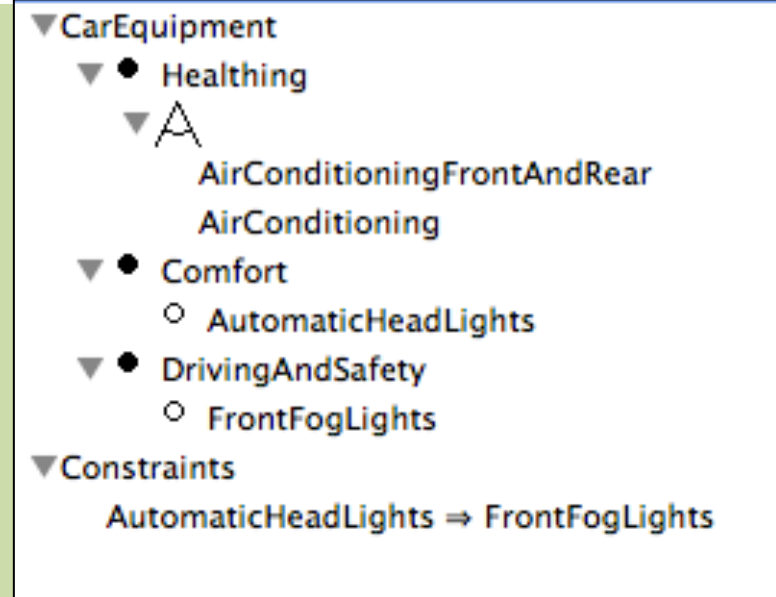
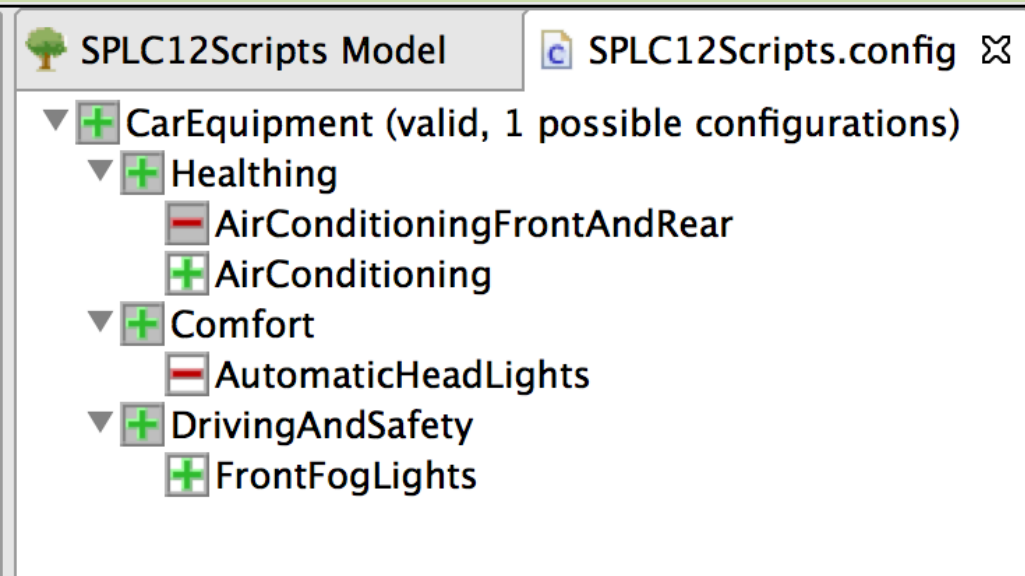

Hierarchy + Variability = set of valid configurations

configuration = set of features selected

{CarEquipment, Comfort, DrivingAndSafety, Healthing, AirConditioning, FrontFogLights}



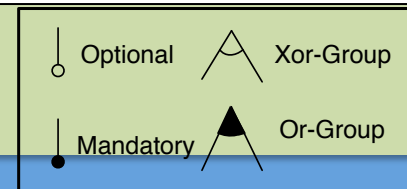
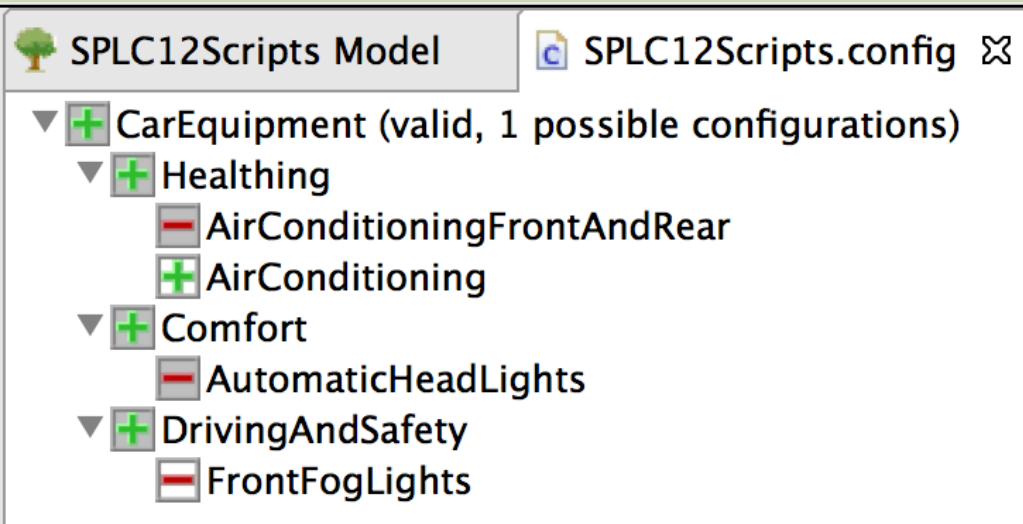

Hierarchy + Variability = set of valid configurations

configuration = set of features selected

{CarEquipment, Comfort, DrivingAndSafety, Healthing, AirConditioning}



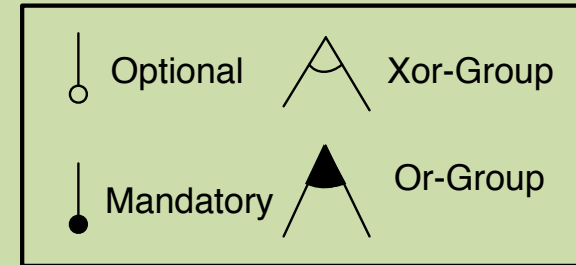
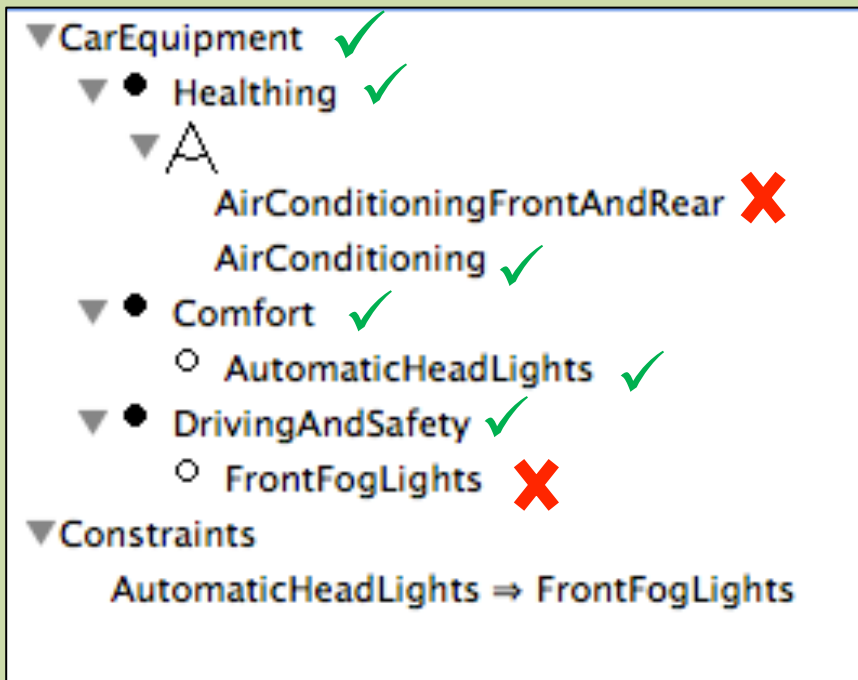

Hierarchy + Variability = set of valid configurations

configuration = set of features selected

{CarEquipment, Comfort, DrivingAndSafety, Healthing, AirConditioning, AutomaticHeadLights}



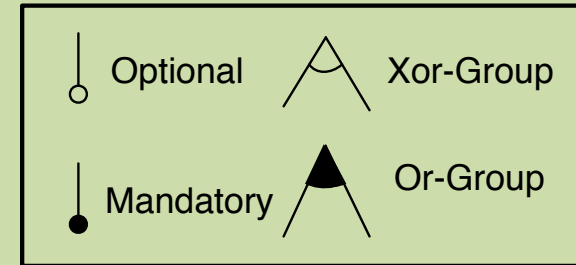
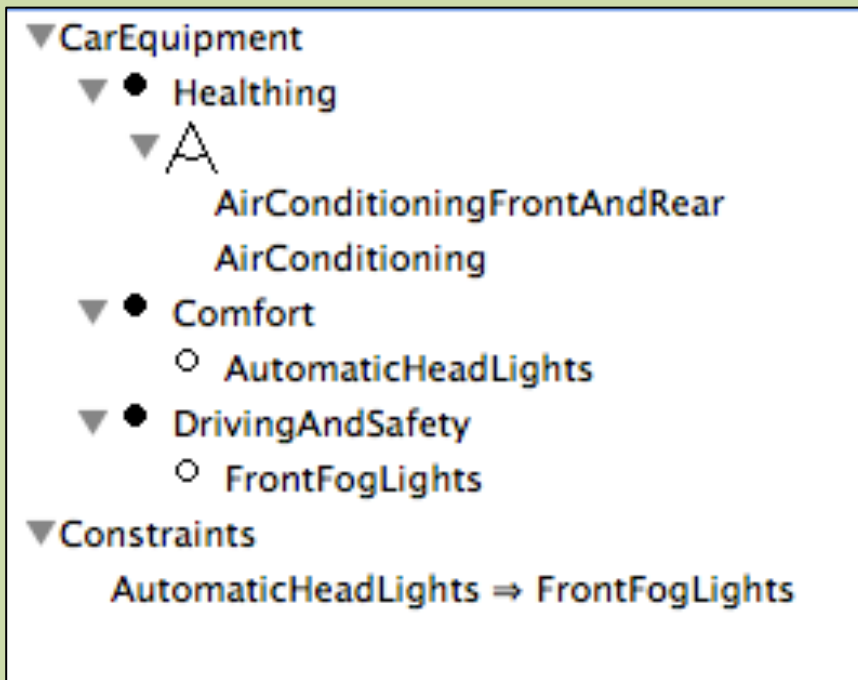

Hierarchy + Variability

=

set of valid configurations



{CarEquipment, Comfort, DrivingAndSafety, Heating}

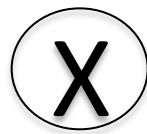

- {AirConditioning, FrontFogLights}
- {AutomaticHeadLights, AirConditioning, FrontFogLights}
- {AutomaticHeadLights, FrontFogLights, AirConditioningFrontAndRear}
- {AirConditioningFrontAndRear}
- {AirConditioning}
- {AirConditioningFrontAndRear, FrontFogLights}

Typical implementations

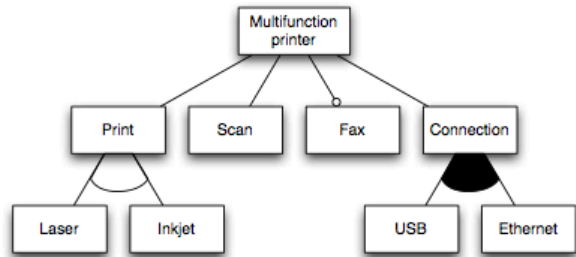

result



logics



solvers



Z3

Learning Feature Models with



(a.k.a implementing the introductory
example)

FAMiliAR

(FeAture Model script Language for manipulation and Automatic Reasoning)

<http://familiar-project.github.com/>



TVL
DIMACS

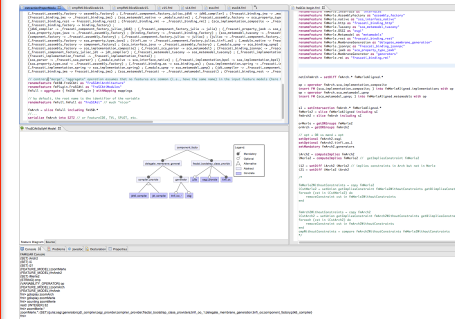
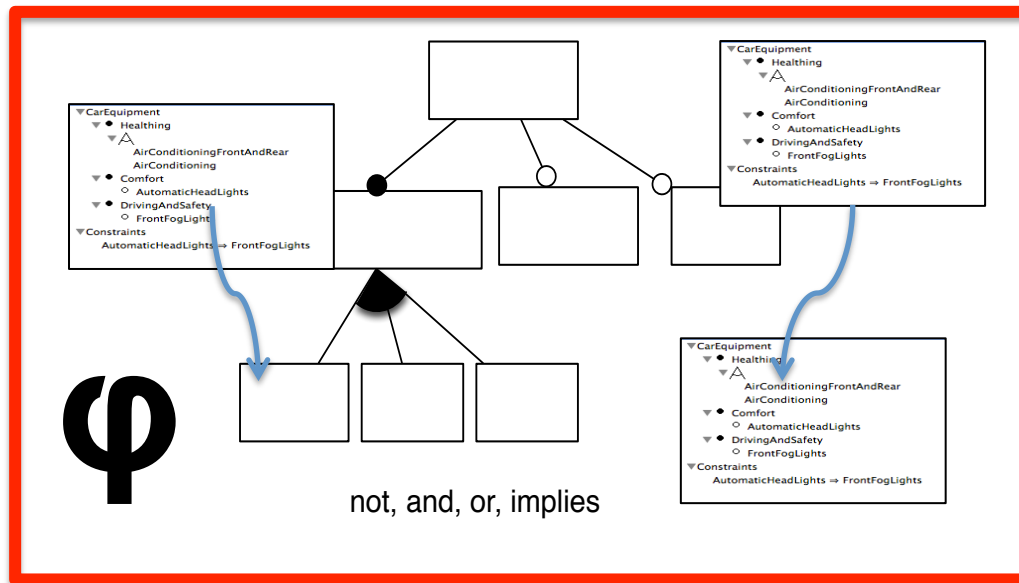

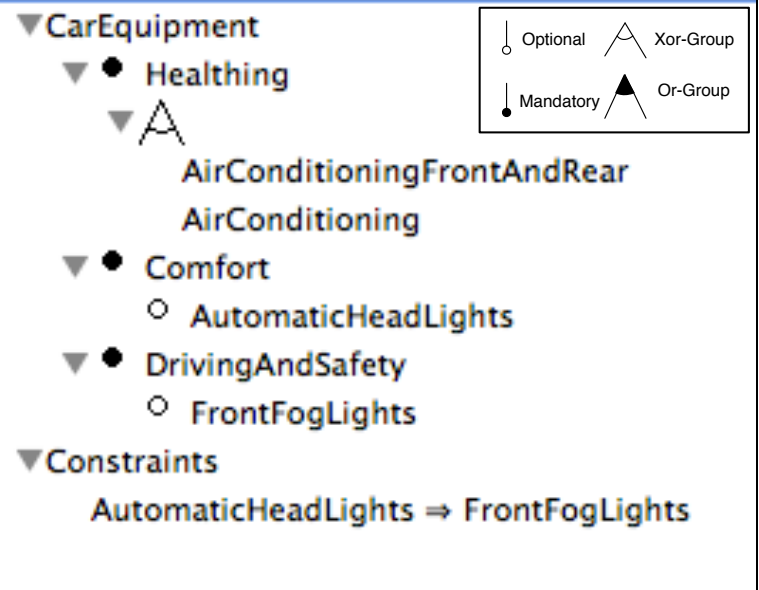

```
fml> convert fmCarEquipment into SPLOT
res1: (STRING) <feature_model name="fmCarEquipment">
<meta>
<data name="description"/>
<data name="creator"/>
<data name="address"/>
<data name="email"/>
<data name="phone"/>
<data name="website"/>
<data name="organization"/>
<data name="department"/>
<data name="date"/>
<data name="reference"/>
</meta>
<feature_tree>
:r CarEquipment(_r0)
  :m Healthing(_r1)
    :g [1,1]
      : AirConditioningFrontAndRear(_r2)
        : AirConditioning(_r3)
      :m DrivingAndSafety(_r4)
        :o FrontFogLights(_r5)
      :m Comfort(_r6)
        :o AutomaticHeadLights(_r7)
</feature_tree>
<constraints>
C0:~_r7 or _r5
</constraints>
</feature_model>
```



CarEquipment ;

ty ;

IDE

eature

```
fmCarEquipment = FM (CarEquipment : Healthing DrivingAndSafety Comfort ; // 3 mandatory features
Healthing : (AirConditioning|AirConditioningFrontAndRear) ; // Xor
DrivingAndSafety : [FrontFogLights] ; // optional
Comfort : [AutomaticHeadLights] ; // optional
// cross-tree constraints
AutomaticHeadLights -> FrontFogLights ; )
```

```
MacBook-Pro-de-Mathieu-3:Documents macher1$ java -Xmx1024M -jar FML-basic-1.1.jar FMLTestRepository/carEquipTuto.fml
FAMILIAR (for FeAture Model scriPt Language for manIPulation and Automatic Reasoning) version 1.1 (beta)
http://familiar-project.github.com/
fml> ls
(FEATURE_MODEL) fmCarEquipment
fml>
```

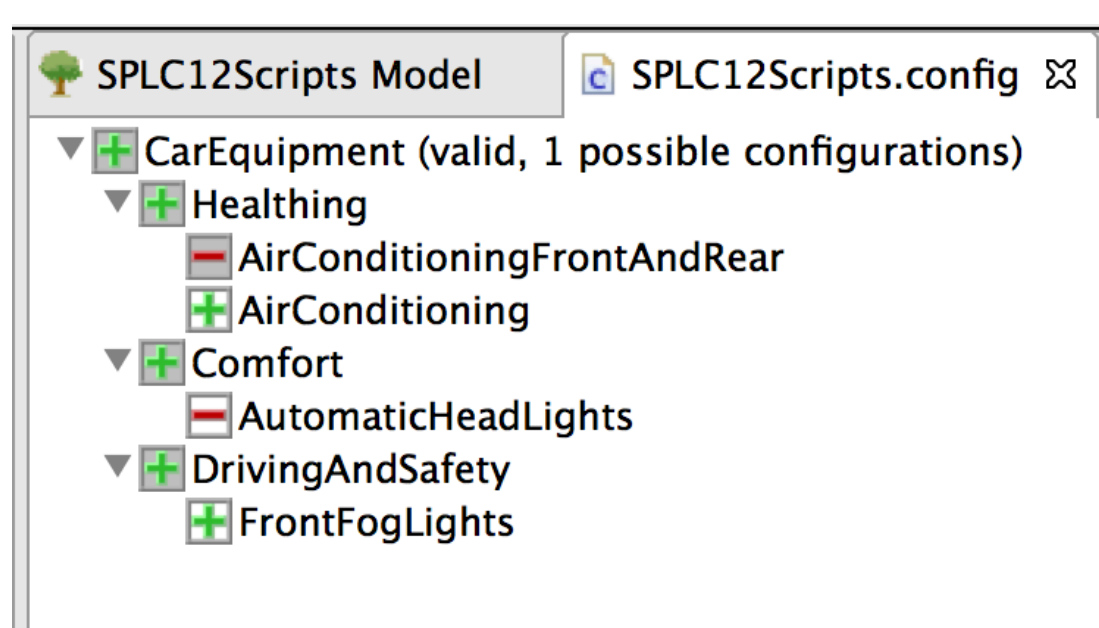
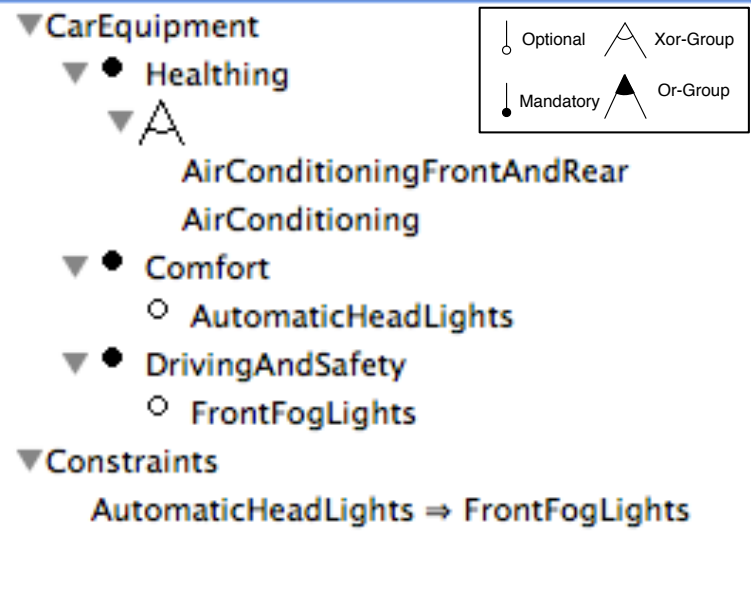

```
fmCarEquipment = FM (CarEquipment : Healthing DrivingAndSafety Comfort ; // 3 mandatory features
                    Healthing : (AirConditioning|AirConditioningFrontAndRear) ; // Xor
                    DrivingAndSafety : [FrontFogLights] ; // optional
                    Comfort : [AutomaticHeadLights] ; // optional
                    // cross-tree constraints
                    AutomaticHeadLights -> FrontFogLights ; )
```

```
fml> c1 = configuration fmCarEquipment
c1: (CONFIGURATION) selected: [Healthing, CarEquipment, DrivingAndSafety, Comfort]      deselected: []
fml> select AirConditioning FrontFogLights in c1
res2: (BOOLEAN) true
fml> deselect AutomaticHeadLights in c1
res3: (BOOLEAN) true
fml> selectedF c1
res4: (SET) {Comfort;CarEquipment;Healthing;AirConditioning;DrivingAndSafety;FrontFogLights}
```

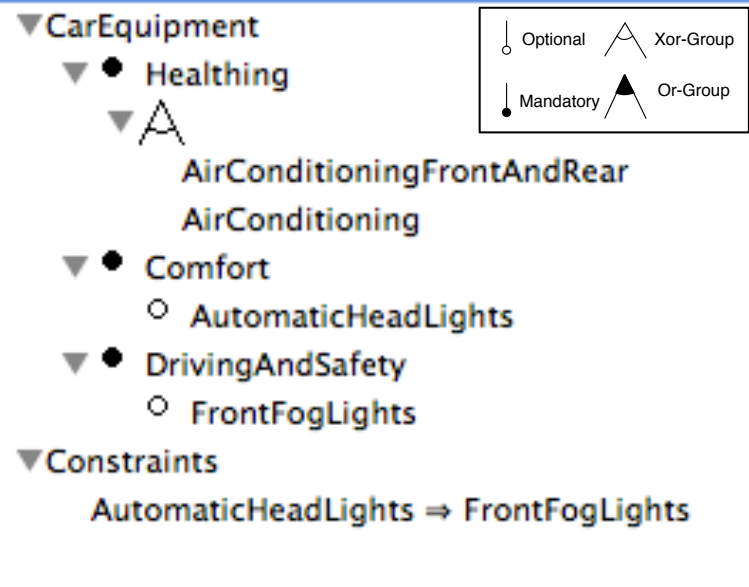

{CarEquipment, Comfort,
DrivingAndSafety,
Healthing}

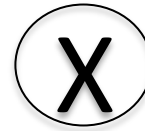

{AirConditioning, FrontFogLights}
 {AutomaticHeadLights, AirConditioning,
 FrontFogLights}
 {AutomaticHeadLights, FrontFogLights,
 AirConditioningFrontAndRear}
 {AirConditioningFrontAndRear}
 {AirConditioning}
 {AirConditioningFrontAndRear, FrontFogLights}

```
fmCarEquipment = FM (CarEquipment : Healthing DrivingAndSafety Comfort ; // 3 mandatory features
                    Healthing : (AirConditioning|AirConditioningFrontAndRear) ; // Xor
                    DrivingAndSafety : [FrontFogLights] ; // optional
                    Comfort : [AutomaticHeadLights] ; // optional
                    // cross-tree constraints
                    AutomaticHeadLights -> FrontFogLights ; )
```

```
fml> co = cores fmCarEquipment
co: (SET) {CarEquipment;Healthing;DrivingAndSafety;Comfort}
fml> fmCarEquipment.*
res6: (SET) {DrivingAndSafety;AirConditioningFrontAndRear;Comfort;Healthing;FrontFogLights;AirConditioning;AutomaticHeadLights;CarEquipment}
fml> setDiff fmCarEquipment.* co
res7: (SET) {AutomaticHeadLights;FrontFogLights;AirConditioning;AirConditioningFrontAndRear}
fml>
res1: (DOUBLE) 6.0
```

```
// carEquipTuto.fml
fmCarEquipment = FM ("carEquip.fml")

c1 = configuration fmCarEquipment
select AirConditioning FrontFogLights in c1
deselect AutomaticHeadLights in c1
s0 = selectedF c1

s1 = configs fmCarEquipment // configuration set
n1 = size s1
n2 = counting fmCarEquipment // efficient way, se
assert (n2 eq n1)

co = cores fmCarEquipment // features necessarily
vp = setDiff fmCarEquipment.* co
//
```



Much more than that!

Let us have a deeper look

FAMiliAR

(FeAture Model script Language for manipulation and Automatic Reasoning)

<http://familiar-project.github.com/>

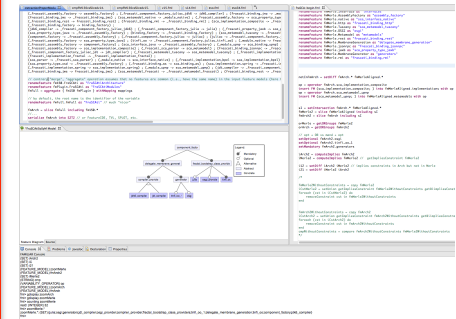
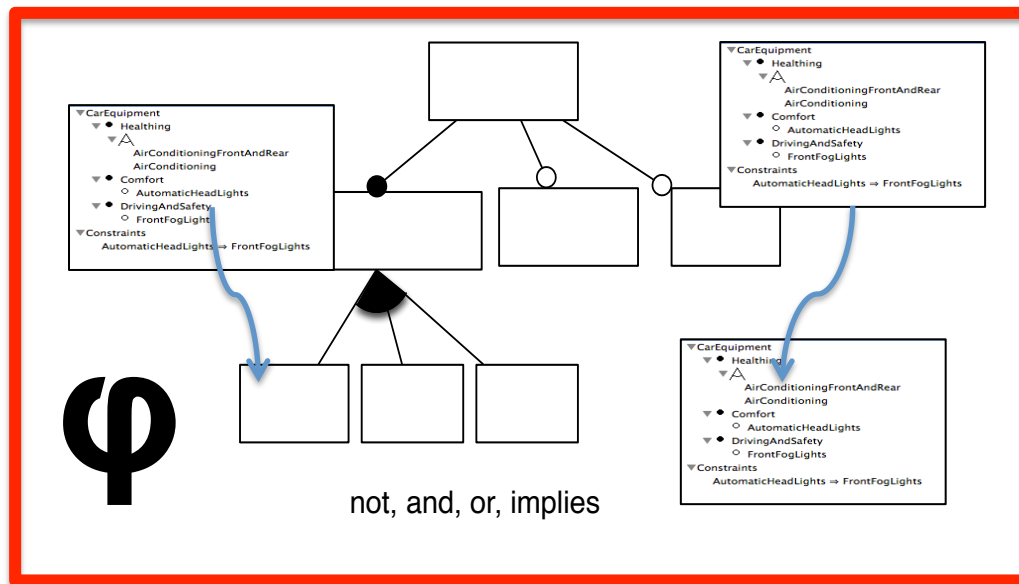

importing, exporting, composing, decomposing, editing, configuring, reverse engineering, computing "difs", refactoring, testing, and reasoning about (multiple) variability models

Importing/Exporting feature models

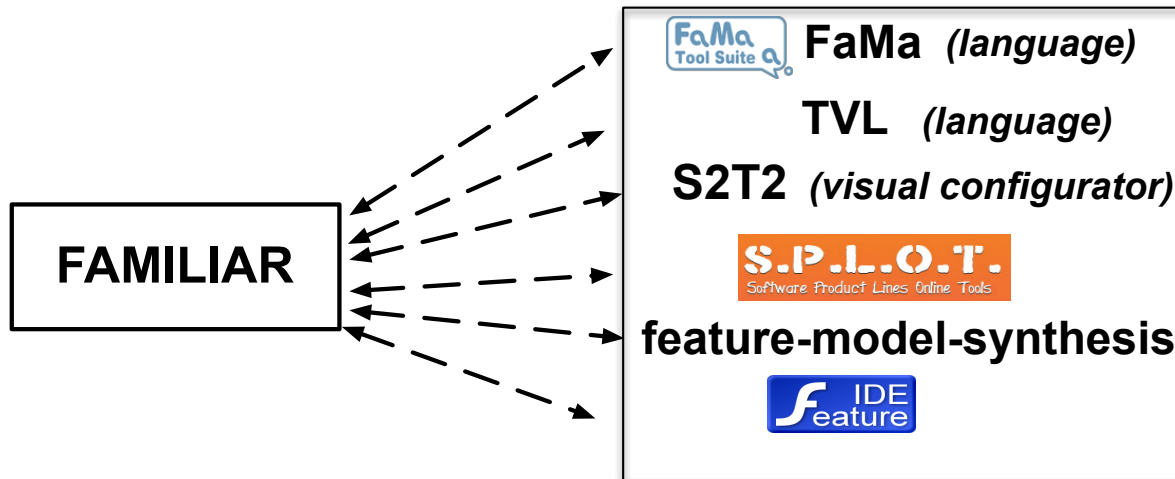

Internal notation *or* by “filename extensions”

```
fm1 = FM ( "foo1.tvl" )
```

```
fm2 = FM ( A : [B] [C] D ; )
```

```
fm3 = FM ( "foo2.m" )
```

```
serialize fm2 into SPLOT // export
```

Configuration

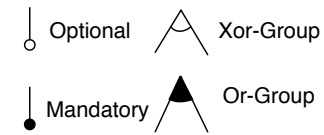

```
fml = FM (A: B [C] [D] E; D : (F|G) ; E : (I|J|K|L) ; C -> !D ; )
c1 = configuration fml
select C in c1
scl = selectedF c1 // accessors
cFM1 = asFM c1 // configuration and FM: back!
```

```
MacBook-Pro-de-Mathieu-2:FML-scripts macher$ java -jar -Xmx1024M ../FML-0.9.9
FAMILIAR (for FeATure Model scriPt Language for manIPulation and Automatic Re
University of Nice Sophia Antipolis, UMR CNRS 6070, I3S Laboratory
https://nyx.unice.fr/projects/familiar/
fml> cFM1
cFM1: (FEATURE_MODEL) A: B E C ;
E: (J|L|I|K) ;
E;
A;
B;
C;
fml> fm1
fm1: (FEATURE_MODEL) A: [D] B E [C] ;
D: (F|G) ;
E: (J|L|I|K) ;
(C -> !D);
```

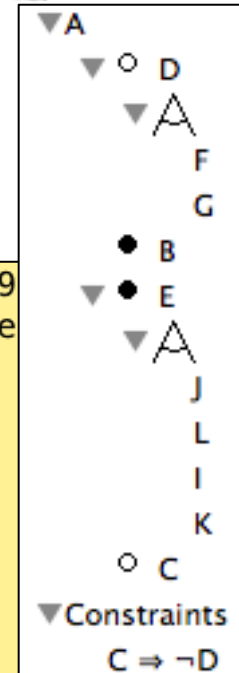

$A \wedge$
 $A \Leftrightarrow B \wedge$
 $C \Rightarrow A \wedge$
 $D \Rightarrow A$

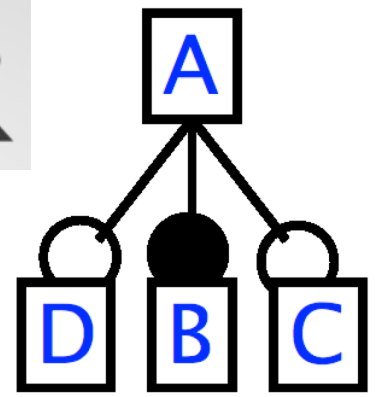

FM

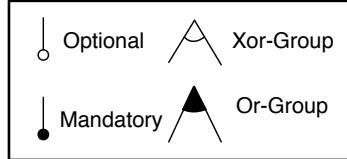

```

fm1bis = FM ("foo3.dimacs")
fm1bisbis = FM ("foo3.constraints")
  
```

```

fm1> fm1 = FM ("output/fm1.tvl")
root A {
  group [ 3..3 ] {
    opt D {
    },
    B {
    },
    opt C {
    }
  }
}
fm1: (FEATURE_MODEL) A: [D] B [C] ;
  
```

```

fm1> c1 = cores fm1
fm1> s1 c1: (SET) {B;A}
s1: (SET) {B;A}
fm1> c1bis = cores fm1bis
c1bis: (SET) {B;A}
fm1> compare fm1 fm1bis
res7: (STRING) REFACTORING {B;A;B;D}}
fm1> compare fm1bis fm1bisbis
res8: (STRING) REFACTORING {B;A};{B;A}}
fm1> s1 res3: (fm1> c1 eq c1bisbis)
res3: (BOOLEAN) true
fm1> s1 res6: (BOOLEAN) true
res4: (BOOLEAN) true
  
```

Operations for Feature Models (1)

```
fm1 = FM (A : [B] [C] ; B -> !C ; B and C ; )
b1 = isValid fm1
```

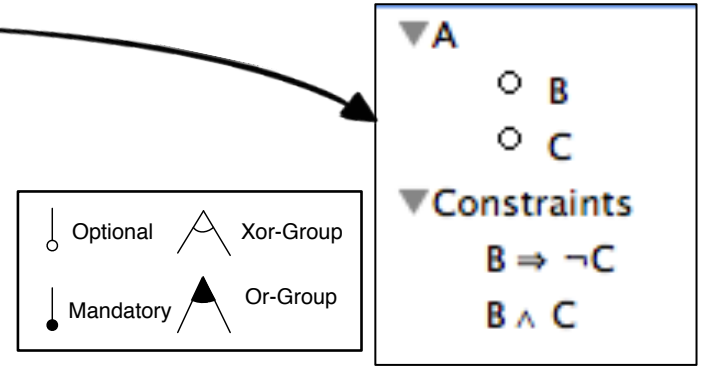

```
acher-scr:FML-scripts macher$ java -jar -Xmx1024M ../FML-0.9.9.5.jar operatorsFM.fml
FAMILIAR (for FeAture Model sCript Language for maNIpulation and Automatic Reasoning)
University of Nice Sophia Antipolis, UMR CNRS 6070, I3S Laboratory
https://nyx.unice.fr/projects/familiar/
fml> ls
(FEATURE_MODEL) fm1
(BOOLEAN) b1
fml> b1
b1: (BOOLEAN) false
fml> configs fm1
res0: (SET) {}
```



Operations for Feature Models (2)

```

1 fm1 = FM (W : P (T|U); P : (R|S)+ ; T : [V] [A] ; R -> !V ; S -> U ; R -> A ; )
2 b1 = isValid fm1
3 s1 = configs fm1
4 c1 = counting fm1
5 dfm1 = deads fm1
6 println "cores: ", cores fm1
7 fo1 = falseOptionals fm1

```

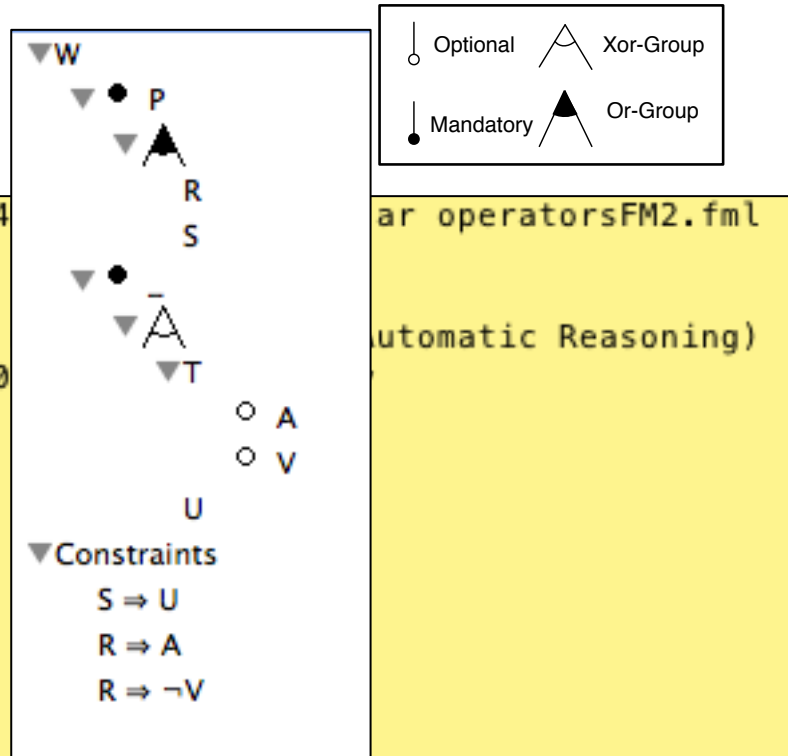

```

macher-scr:FML-scripts macher$ java -jar -Xmx1024
cores: {P;W}

FAMILIAR (for FeAture Model scriPt Language for
University of Nice Sophia Antipolis, UMR CNRS 60
https://nyx.unice.fr/projects/familiar/
fml> ls
(SET) fo1
(SET) dfm1
(SET) s1
(DOUBLE) c1
(BOOLEAN) b1
(FEATURE_MODEL) fm1
fml> c1
c1: (DOUBLE) 2.0
fml> fo1
fo1: (SET) {A}
fml> dfm1
dfm1: (SET) {V}

```

```

ar operatorsFM2.fml
Automatic Reasoning)

```



Operations for Feature Models (3)

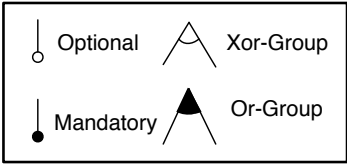

```
fml = FM (A : [B] [C] ; B -> !C ; B and C ; )
b1 = isValid fml
```

```
csts1 = constraints fml
foreach (cst in csts1) do
  println "removing constraint... ", cst
  removeConstraint cst in fml
  c = counting fml
  println "now the number of valid configurations is... ", c
end
```

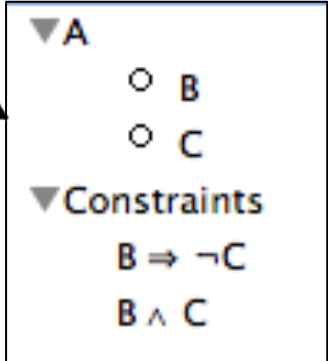

```
MacBook-Pro-de-Mathieu-2:FML-scripts macher$ java -jar -Xmx1024M ../FML-0.9.9.5.jar operatorsFM3.fml
removing constraint... (B & C)

now the number of valid configurations is... 3.0

removing constraint... (B -> !C)

now the number of valid configurations is... 4.0
```

Product Derivation

feature model

variable model and
code assets

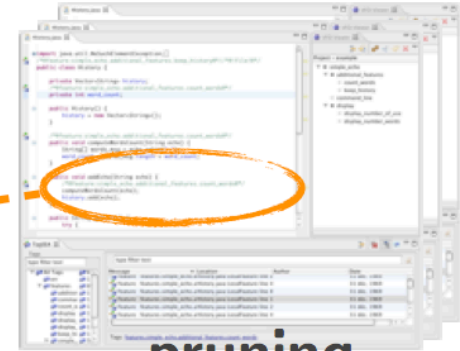
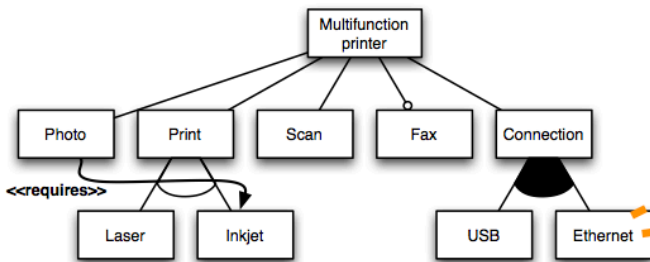

pruning,
composition,
weaving,
transformation
...

configuration

{ MP, Photo, Print, Inkjet, Scan,
Fax, Connection, USB, Ethernet }

product spec

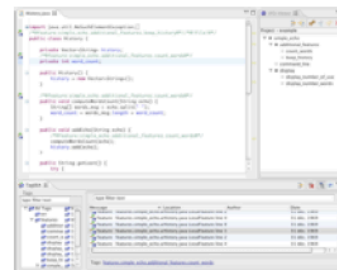

product

Bref
as a product line

Generative approach

- Programming the generation of programs
 - Very old practice
 - Metaprogramming: generative language and target language are the same
 - Reflection capabilities
- Generalization of this idea:
 - from a specification (**model**) written in one or more textual or graphical domain-specific languages
 - you generate **customized variants**

Modeling and implementing system families such that a desired system can be automatically generated from a specification written in one or more textual or graphical domain-specific languages.

Models And Languages

